



THOR-400G-7S-1P

7-speed dual-media test module

Xena's Thor-400G-7S-1P test module can test seven different Ethernet network speeds - 400GE, 200GE, 100GE, 50GE, 40GE, 25GE and 10GE. This unique flexibility is provided via two physical transceiver cages - one supporting QSFP-DD/56/28/+ transceivers, and the other supporting QSFP56/28/+ transceivers.

The QSFP-DD cage can support the following speeds and ports: 1x400G, 1x200G, 1x100G, 2x100G, 4x100G, 2x50G, 4x50G, 1x40G, 4x25G, and 4x10G Ethernet test ports. The QSFP56 cage can support the exact same speeds except for 400G Ethernet and 4x100G Ethernet. Both cages can be active simultaneously except when the QSFP-DD cage runs 400GE or 4 x 100GBASE-DR.

Thor-400G-7S-1P is unique on the market with its ability to test both NRZ & PAM4 speeds, plus perform Auto-Negotiation and Link Training (AN/LT) with a comprehensive level of interoperability testing.

The result is a highly versatile solution for performance and functional testing of network infrastructure and Ethernet equipment that support 400GE including switches, routers, NICs, TAPs, packet-brokers, and backhaul platforms.

TOP FEATURES

- 7-speed flexibility: 400GE, 200GE, 100GE, 50GE, 40GE, 25GE and 10GE
- Dual media value
- Supports both NRZ & PAM4 speeds
- Support for Auto-neg & Link Training (AN/LT) - interoperability tested
- Price/performance
- Ease of use
- Free software (incl. ValkyrieManager, ValkyrieCLI, Valkyrie2544, Valkyrie1564, Valkyrie3918, and Valkyrie2889)
- Three years' free software updates
- Three years' free hardware warranty
- Free tech support product lifetime

The Thor-400G-7S-1P can test 400GE, 200GE, 100GE, 50GE, 40GE, 25GE and 10GE

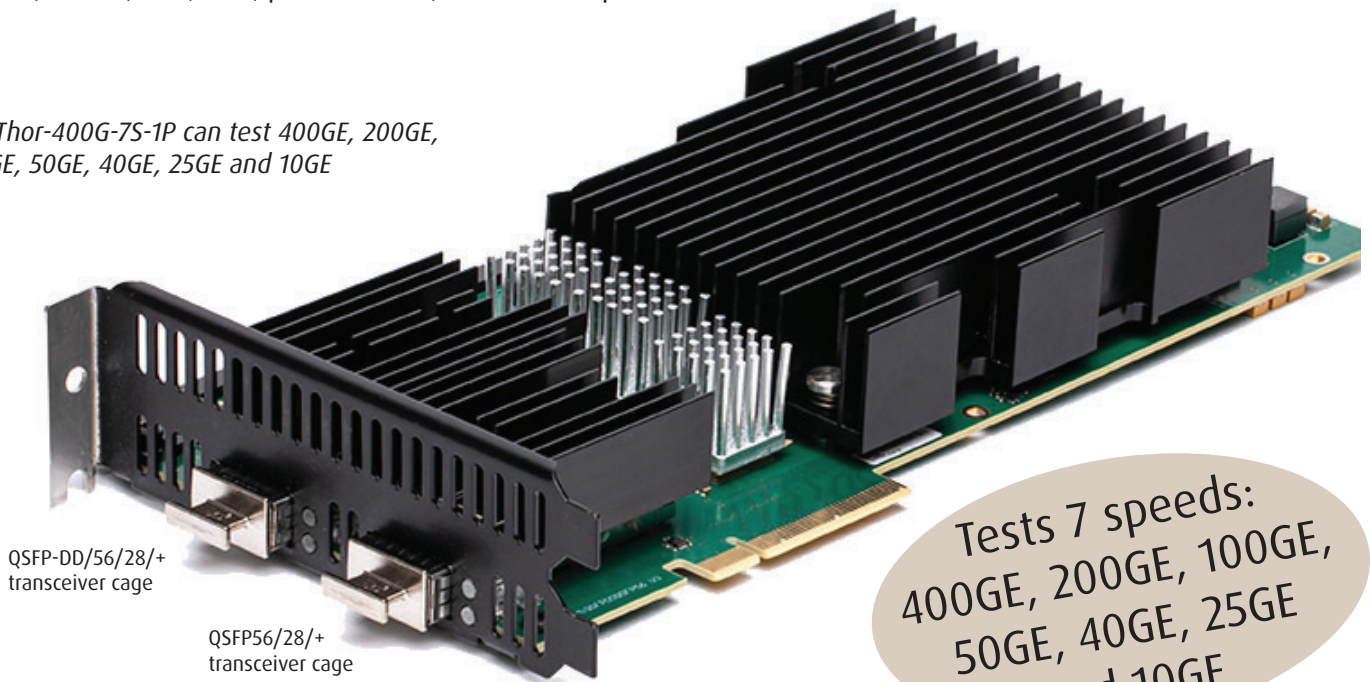

PORT LEVEL FEATURES

Interface category	QSFP-DD • 400G, 200G, 100G, 50G Ethernet QSFP56 • 200G, 100G, 50G Ethernet QSFP28 • 100G, 50G, 40G*, 25GE and 10G* Ethernet QSFP+ • 40G, 10G Ethernet
	* Depending on transceiver capabilities
Total number of test ports (software configurable)	1x400G, 2x200G, 4x100G, 8x50G, 2x40G, 8x25G, and 8x10G Ethernet



Interface options	Line code	Standard
QSFP-DD cage	<ul style="list-style-type: none"> • 1 x 400GBASE-DR4, 1 x 400GBASE-SR8/FR8/LR8, or PAM4 802.3bs • 2 x 200GBASE-CWDM4 (dual CS connector), or PAM4 802.3bs/802.3cd • 1 x 200GBASE-CR8, or PAM4 802.3cd • 1 x 200GBASE-DR4/SR4/FR4/LR4/CR4, or PAM4 802.3bs/802.3cd • 4 x 100GBASE-CR2, or 4 x 100GBASE-DR, or PAM4 802.3cd • 2 x 100GBASE-SR2/CR2, 2 x 100GBASE-DR (dual CS connector) or PAM4 802.3cd • 1 x 100GBASE-SR4/LR4/CR4, or NRZ 802.3bj • 8 x 50GBASE-SR/CR, or PAM4 802.3cd • 4 x 50GBASE-SR/CR, or PAM4 802.3cd • 2 x 50GBASE-SR2/LR2/CR2, or NRZ Consortium** • 1 x 40GBASE-SR4/LR4/CR4, or NRZ 802.3ba • 4 x 25GBASE-SR/LR/CR, or NRZ 802.3by/Consortium** • 4 x 10GBASE-SR/LR/CR NRZ 802.3ae 	
QSFP56 cage	<p>Same as QSFP-DD minus support for 400G speeds, 2 x 200GBASE-CWDM4, 1 x 200GBASE-SR8, 4 x 100GBASE-DR, 4 x 100GBASE-CR2 and 8 x 50GBASE-SR/CR. In addition, the QSFP56 does currently not support 2 x 100GBASE-DR/SR2/CR2</p> <p>Actual interface options depend on the capabilities of the inserted transceiver. Both cages can be active simultaneously except when the QSFP-DD cage runs 400GE, 2 x 200GBASE-CWDM4, 1 x 200GBASE-SR8, 4 x 100GBASE-DR or 8 x 50GBASE-SR/CR. Both cages must run with the same base interface configuration (e.g. 2 x 50G). Power capacity per QSFP-DD/QSFP56 cage: 15 watts.</p> <p>** As defined by 25/50 GigabitEthernet Consortium</p>	
Auto Negotiation and Link Training	IEEE 802.3 Clause 73, Auto-negotiation IEEE 802.3 Clause 72, Link training	
Forward Error Correction (FEC)	RS-FEC (Reed Solomon) FEC, IEEE 802.3 Clause 119 (200/400GE) RS-FEC (Reed Solomon) FEC, IEEE 802.3 Clause 91 (100GE) RS-FEC (Reed Solomon) FEC, IEEE 802.3 Clause 134 (50GE 802.3cd) RS-FEC (Reed Solomon) FEC, IEEE 802.3 Clause 108 (25GE) RS-FEC (Reed Solomon) FEC, 25/50G Ethernet Consortium (25/50GE)	
Number of transceiver module cages	1xQSFP-DD/QSFP56/QSFP28/QSFP+ and 1xQSFP56/QSFP28/QSFP+	
Port statistics	Link state, FCS errors, pause frames, ARP/PING, error injections, training packet All traffic: RX and TX Mbit/s, packets/s, packets, bytes Traffic w/o test payload: RX and TX Mbit/s, packets/s, packets, bytes	
Adjustable Inter Frame Gap (IFG)	Configurable from 16 to 56 bytes, default is 20B (12B IFG + 8B preamble)	
Transmit line rate adjustment	Ability to adjust the effective line rate by forcing idle gaps equivalent to -1000 ppm (increments of 10 ppm)	
Transmit line clock adjustment	From -400 to 400 ppm in steps of 0.001 ppm (shared across all ports)	
ARP/PING	Supported (configurable IP and MAC address per port)	
Field upgradeable	System is fully field upgradeable to product releases (FPGA images and software)	
Tx disable	Enable/disable of optical laser or copper link	
IGMPv2 multicast join/leave	IGMPv2 continuous multicast join, with configurable repeat interval	
Histogram statistics	Two real-time histograms per port. Each histogram can measure one of RX/TX packet length, IFG, or Latency distribution for all traffic, a specific stream, or a filter	
Loopback modes	<ul style="list-style-type: none"> • L1RX2TX – RX-to-TX, transmit byte-by-byte copy of the incoming packet • L2RX2TX – RX-to-TX, swap source and destination MAC addresses (*only at 10G) • L3RX2TX – RX-to-TX, swap source and destination MAC addresses and IP addresses (*only at 10GE) • TXON2RX – TX-to-RX, packet is also transmitted from the port • TXOFF2RX – TX-to-RX, port's transmitter is idle • Port-to-port – Inline loop mode where all traffic is looped 100% transparent at L1 (All rates except 400GE) 	
Oscillator characteristics	<ul style="list-style-type: none"> • Initial Accuracy is 3 ppm • Frequency drift over 1st year: +/- 3 ppm (over 15 years: +/- 15 ppm) • Temperature Stability: +/- 20 ppm (Total Stability is +/- 35 ppm) 	

400/200/100/50/40/25GE FRAMED PRBS AND PCS LAYERS

Payload Test pattern	PRBS 2 ³¹
Error Injection	Manual single shot bit-errors or bursts, automatic continuous error injection
Frame size and header	Fixed size from 56 to 12228 bytes, any layer 2/3/4 frame header
Alarms	Pattern loss
Error analysis	Bit-errors: seconds, count, rate
PCS virtual lane configuration	User-defined skew insertion per Tx virtual lane, and user defined virtual lane to SerDes mapping for testing of the Rx PCS virtual lane re-order function.
PCS virtual lane statistics	Relative virtual lane skew measurement (up to 2048 bits), sync header and PCS lane marker error counters, indicators for loss of sync header and lane marker, BIP8 errors

NOTE: Text in blue are features that will be added soon.



TRANSMIT ENGINES

Number of transmit streams per port	Initially 256 (wire-speed). This will be increased to 512 streams. Each stream can generate millions of traffic flows using field modifiers
Test payload insertion per stream	Wire-speed packet generation with timestamps, sequence numbers, and data integrity signature optionally inserted into each packet.
Stream statistics	TX Mbit/s, packets/s, packets, bytes, FCS error, Pause
Bandwidth profiles	Burst size and density can be specified. Uniform and bursty bandwidth profile streams can be interleaved
Field modifiers	16-bit header field modifiers with inc, dec, or random mode. Each modifier has configurable bit-mask, repetition, min, max, and step parameters. 8 modifiers per stream
Packet length controls	Fixed, random, butterfly, and incrementing packet length distributions from 56 to 12288 bytes
Packet payloads (basic)	Repeated user specified 1 to 18B pattern, an 8-bit incrementing pattern
Extended Payload	Fixed full custom payloads can be generated for each stream with payload sizes up to 12288 bytes
Custom Data Fields	Custom sequences of payloads can be generated for each stream, using several megabytes of custom payload storage available on each port.
Error generation	Undersize length (56 bytes min) and oversize length (12288 bytes max.) packet lengths, injection of sequence, misorder, payload integrity, and FCS errors
TX packet header support and RX autodecodes	Ethernet, Ethernet II, VLAN, ARP, IPv4, IPv6, UDP, TCP, LLC, SNAP, GTP, ICMP, RTP, RTCP, STP, MPLS, PBB, or fully specified by user
Packet scheduling modes	<ul style="list-style-type: none"> • Normal (stream interleaved mode) – standard scheduling mode, precise rates, minor variation in packet inter-frame gap. • Strict Uniform – new scheduling mode, with 100% uniform packet inter-frame gap, minor deviation from configured rates. • Sequential packet scheduling (sequential stream scheduling). Streams are scheduled continuously in sequential order, with configurable number of packets per stream. • Burst. Packets in a stream are organized in bursts. Bursts from active streams form a burst group. The user specifies time from start of one burst group till start of next burst group.

RECEIVE ENGINE

Number of traceable Rx streams per port	2016 (wire-speed)
Automatic detection of test payload for received packets	Real-time reporting of statistics and latency, loss, payload integrity, sequence error, and misorder error checking
Jitter measurement	Jitter (Packet Delay Variation) measurements compliant to MEF10 standard with 8 ns accuracy Jitter can be measured on up to 32 streams
Stream statistics	<ul style="list-style-type: none"> • RX Mbit/s, packets/s, packets, bytes. • Loss, payload integrity errors, sequence errors, misorder errors • Min latency, max latency, average latency • Min jitter, max jitter, average jitter
Latency measurements accuracy	±32 ns
Latency measurement resolution	8 ns (<i>Latency measurements can calibrate and remove latency from transceiver modules</i>)
Number of filters:	<ul style="list-style-type: none"> • 4 x 64-bit user-definable match-term patterns with mask, and offset • 4 x frame length comparator terms (longer, shorter) • 4 x user-defined filters expressed from AND/OR'ing of the match and length terms.
Filter statistics	Per filter: RX Mbit/s, packets/s, packets, bytes.

CAPTURE

Capture criteria	All traffic, stream, FCS errors, filter match, or traffic without test payloads
Capture start/stop triggers	Capture start and stop trigger: none, FCS error, filter match
Capture limit per packet	16 - 12288 bytes
Wire-speed capture buffer per port	384 kB for 400GE 192 kB for 200GE 96 kB for 100GE 48 kB for 50GE 48 kB for 40GE 32 kB for 25GE 16 kB for 10GE
Low speed capture buffer per port (10Mbit/s speed)	4096 packets (any size)

ADVANCED PHY FEATURES

Equalization Controls	Tx Transmit Equalization Controls <ul style="list-style-type: none"> • Pre-emphasis • Tx Attenuation • Tx Post-emphasis Signal Integrity Analysis Optional Auto-Tune of Rx equalizer/CTLE
Signal Integrity Analysis	• FEC error correction chart

NOTE: Text in **blue** are features that will be added soon.



One module - multiple options

The Thor-400G-7S-1P has 2 transceiver cages. The type of transceiver that is used, determines the speeds and number of ports you can use. The port number / speed configuration must be the same for both cages.

This is defined using ValkyrieManager, the traffic generation and analysis software provided by Xena with all Valkyrie test systems.

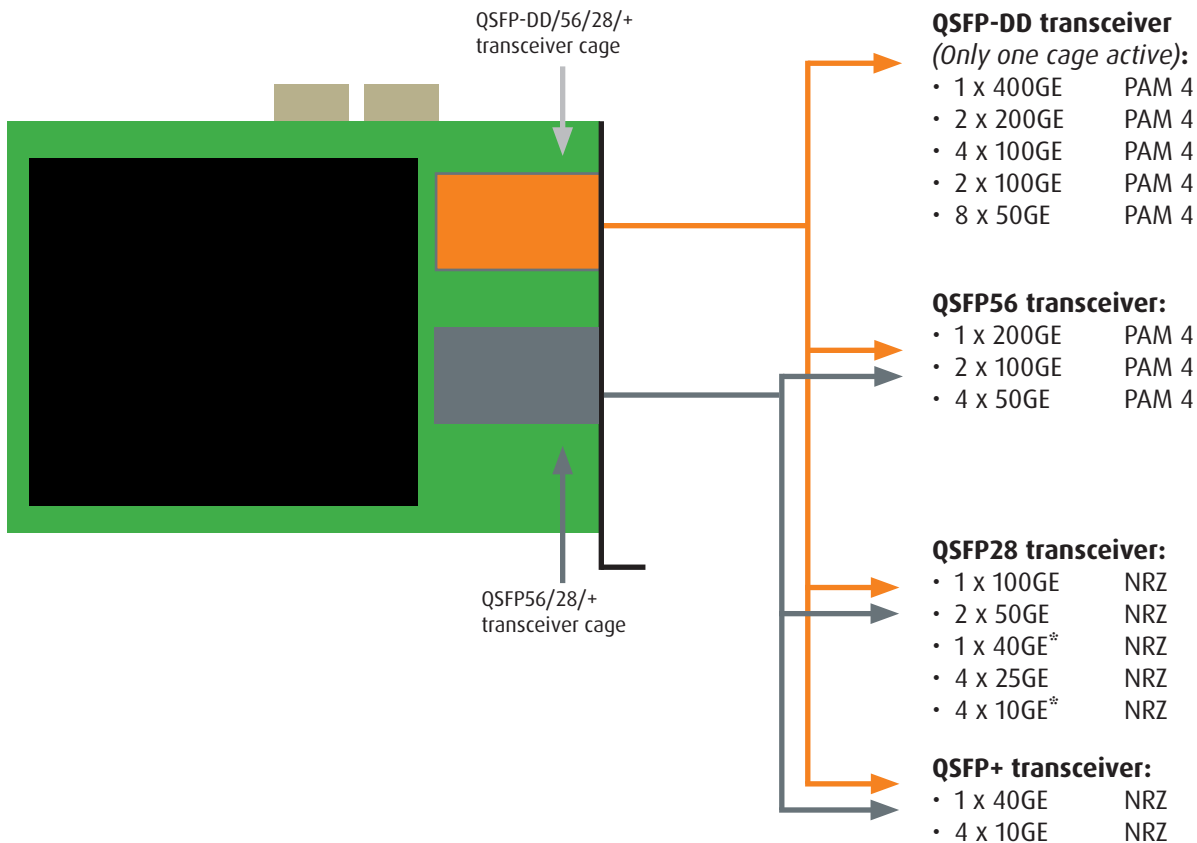

* Depending on transceiver capabilities

SPECIFICATIONS

Dimensions

1U ValkyrieCompact

- W: 19" (48.26 cm)
- H: 1.75" (4.45 cm)
- D: 9.8" (25 cm)
- Weight: 10 lbs (4.5 kg)

4U ValkyrieBay (2 slots)

- W: 19" (48.26 cm)
 - H: 7" (17.78 cm)
 - D: 19.7" (50 cm)
 - Weight: 36.4 lbs (16.5 kg)
- This module is only supported by the Val-C12-2400 chassis.*

Max. Noise

- ValkyrieCompact: 49 dBa
- ValkyrieBay: 58.5 dBa

Environmental

- Operating Temperature: 10 to 35° C
- Storage Temperature: -40 to 70° C
- Humidity: 8% to 90% non-condensing

Power

- AC Voltage: 100-240V
- Frequency: 50-60Hz
- Max. Power: 90W (ValkyrieCompact) / 120W (ValkyrieBay)
- Max. Current: 0.8A with 120V supply, and 0.4A with 240V supply

Regulatory

- FCC (US), CE (Europe)



www.xenanetworks.com

Sales contact: sales@xenanetworks.com