

The T-BERD 8000 Transport Module

SONET/SDH, PDH, Fibre Channel, OTN, Jitter, Wander and Ethernet Test Module for the T-BERD 8000 platform



Key Features

- Optical GigE and 10 GigE LAN and WAN PHY testing at 850 nm, 1310 nm, and 1550 nm wavelengths
- Ethernet and IP testing with 10/100/1000 Mb/s electrical RJ-45 Interfaces
- Support for VLAN, Q-in-Q, VPLS, MPLS Tunneling applications and IP
- 1G/2G Fibre Channel and FICON support for Storage Area Networks
- Optical SONET/SDH testing for 155 Mb/s, 622 Mb/s, 2.5 Gb/s and 10 Gb/s
- OTN testing at 2.7Gb/s, 10.7Gb/s, 11.05Gb/s and 11.09Gb/s bitrates
- T-carrier and PDH testing with T1, E1, E3, DS3 and E4 interfaces and mappings
- O.172/O.173 compliant Jitter and Wander testing for T1, E1, E3, DS3, E4, STM-1 (e/o) electrical rates as well as 155M, 622M and 2.5G, 2.7G optical interfaces
- Simultaneous and Independent Multi Port SONET, SDH, OTN, Fibre Channel and Ethernet test capable
- Reduction of CAPEX with a stackable design that allows for a cost effective upgrade path
- Identification of Fiber Optics problems faster with the user interface's optical power source, high accuracy power meter, Visual Fault Locator, and Fiber Microscope
- Unique, integrated field solution combining SONET/SDH, PDH, Fibre Channel, OTN, Jitter, Wander and Ethernet technologies in one module, available to the market, weighing less than 15 lbs/7 kilos



Providers are expanding their offerings into new data and wavelength services and test responsibilities are expanding beyond traditional SONET/SDH and PDH needs into next generation IP and OTN-based networks. Users now have the responsibility to install and maintain new network elements and services that were not present in yesterday's legacy networks. The Transport Module addresses these trends by providing the necessary test functionality to support these services in one, integrated module.

Overview

One integrated solution

As new service offerings arise, Multiservice Provisioning Platforms (MSPPs) are combining Data and Transport technologies on the same line cards. These network elements offer providers the flexibility to configure new services quickly to support customer demand. The Transport Module replicates this design by providing Ethernet, OTN, Fibre Channel, Jitter, Wander, SONET/SDH and PDH test functionality in one module, enabling providers to deploy, commission and maintain these new services quickly, efficiently and conveniently. Users are no longer required to carry, and maintain multiple modules or test sets in support of today's service offerings.

Multi-Port BER testing

The Transport Module reduces test times by 66% with simultaneous and independent multi-port testing. Traditional test sets have provided the functionality to test one circuit at a time forcing users to turn-up services sequentially or to use multiple test sets – an ineffective use of resources and time. The Transport Module's simultaneous test capability allows users to BER test three circuits in parallel, and perform dual direction, in line optical monitoring (seeing both East and West directions) for SONET/SDH rings, Fibre Channel and Gigabit Ethernet services.

Battery operation

Taking battery operation to another level, the T-BERD/MTS 8000 is configurable with up to two batteries. Never lose test results in the case of power failures again!!

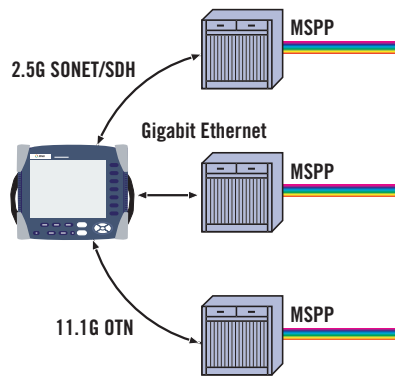
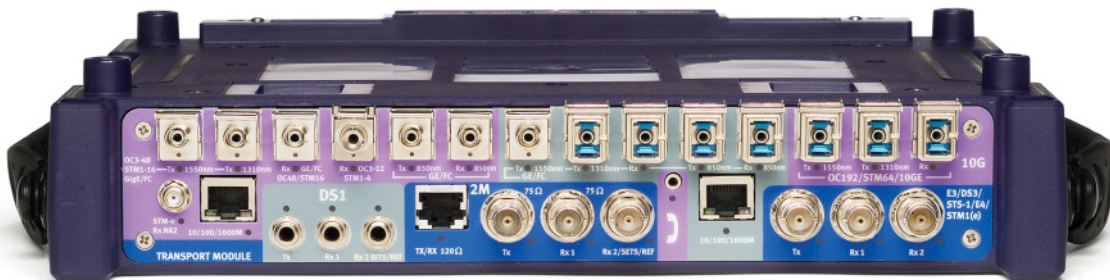

Figure 1 Configuration example showing one of the many possible test combinations



Module overview

Ethernet and IP

The Transport Module supports 10 Mb/s to 10 Gb/s Ethernet (LAN-Phy and WAN-Phy) testing to the IP layer, ensuring that proven test methodologies for Carrier-Ethernet services remain the same regardless of the rate. Test capability ranges from BER testing and verifying end-to-end connectivity to determining whether Throughput, Utilization, Frame Loss, Packet Jitter and Round Trip Delay (RTD) characteristics meet Service Level Agreements (SLAs).

VLAN, Q-in-Q, VPLS and MPLS Tunneling Technologies

Various mechanism and tunneling technologies existing today allow providers to effectively deliver carrier-grade Ethernet services across their networks, while maintaining a specified Class of Service (CoS). These technologies are grouped into two categories:

- Native Ethernet protocol extensions (IEEE based) – VLAN tags (often referred to as 802.1Q/p) and Q-in-Q (often referred to as VLAN Stacking or 802.1ad) techniques
- Encapsulations by Multi Protocol Label Switch (MPLS) networks, which also come in Layer 2 (VPLS) and Layer 3 flavors

The Transport Module enables the installation and service maintenance of these technologies.

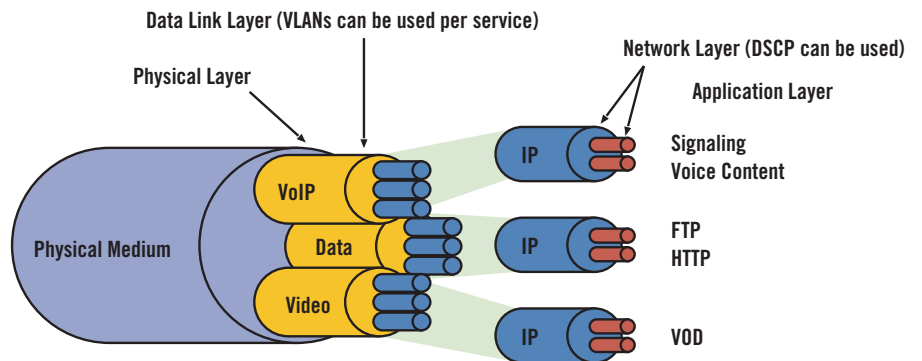

Figure 2 Multiple Data Streams

Quality of Service measurements testing with Multiple Streams

RTD, Packet Jitter, Lost and Out-of-Sequence frame/packet measurements are critical parameters for delay sensitive, real time applications such as Video and Voice over IP (VoIP). The Transport Module verifies services for Packet Jitter, RTD and packet loss for both Ethernet and IP services, ensuring that they conform to SLA parameters.

The evolution of Ethernet as the transport layer for a converged network, combined with the need to provide increasing amounts of bandwidth in support of Triple Play services, creates an increasing focus on Quality of Service (QoS) and resilience on today’s carrier-grade Ethernet networks.

These networks must be scalable, cost-effective, and have the ability to prioritize and process traffic based on the ‘importance of delivery’ to the end user. The industry has designed CoS mappings for various services. Depending on the technology used, this often consists of tagging a certain type of traffic with an ID, and assigning it a priority so that network elements can process this information, and make the appropriate routing decisions.

The Transport Module relies on multiple stream traffic generation, allowing users to emulate various types of traffic with the appropriate CoS mappings, and assess the impact of such traffic on the overall network design.

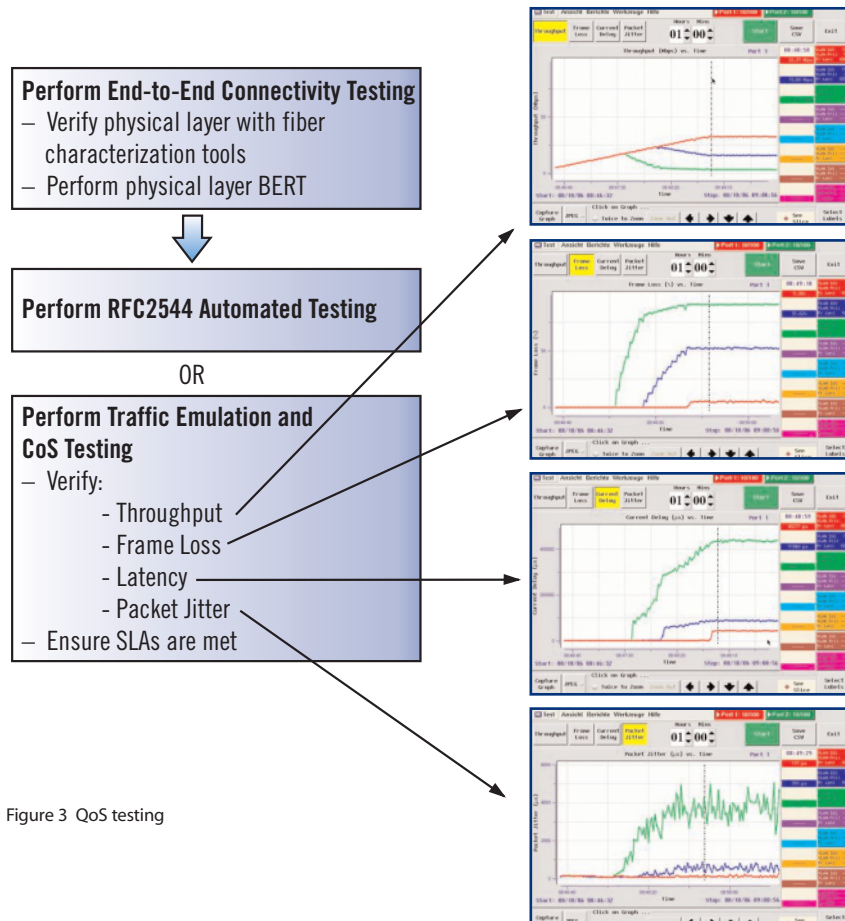

Figure 3 QoS testing

Storage Area Networking

Fibre Channel/ FICON Overview

The 1G and 2G Fibre Channel option allows users to test both Fibre Channel and FICON services. Users can manipulate various fields of the Fibre Channel frames to emulate end-customer traffic, and perform BER measurements on Layer 1 and Layer 2 circuits. The Transport Module supports buffer crediting capability, allowing providers to verify the effect of delay on the link Throughput and test the links ability to obtain the optimum buffer credit values. The Transport Module also allows users to turn up SAN networks efficiently by using the Fibre Channel automated test script producing reliable Throughput, Packet Loss, RTD and Burstability results with a consistent test methodology.

'RFC like' Fibre Channel testing

- Adapts RFC 2544 testing methodology to Fibre Channel circuits
- Allows for automated test routines and results analysis
- Allows for the saving of specific test configurations and routines

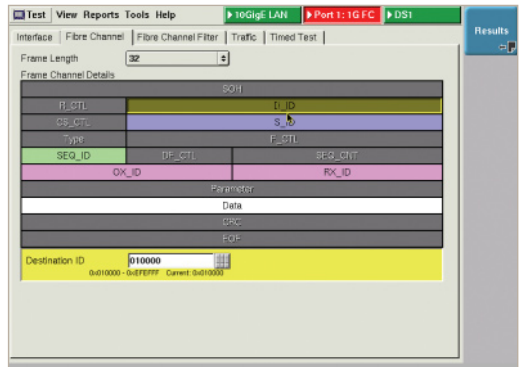

Fibre Channel Frame setup

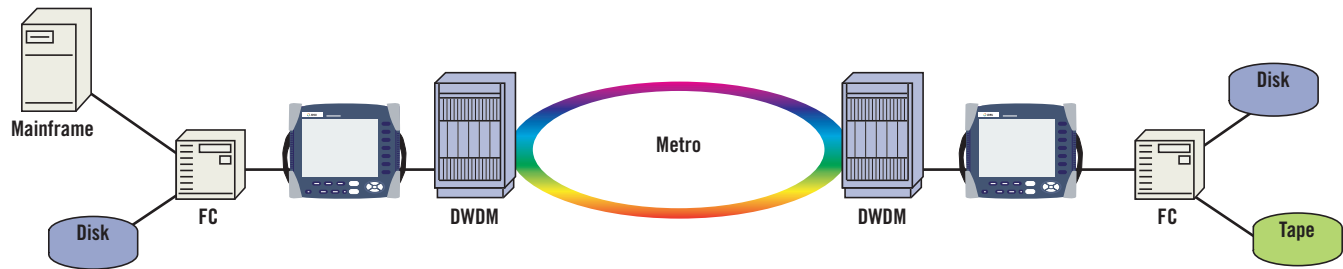

Figure 4 End-to-End Fibre Channel Testing

OTN

The goal of the Optical Transport Network (OTN), otherwise known as digital wrapper technology, is to combine and accelerate the benefits of SONET/SDH with the bandwidth expandability of dense wavelength division multiplexing (DWDM). OTN applies the OAM&P functionality of SONET/SDH, allows for protocol transparency, optimized, error-free transmission, and reduces the number of 3R regeneration points in an optical network. This enables operators to cost effectively install, maintain and scale their next generation networks.

Support OTU-1 (2.7G) and OTU-2 (10.7, 11.05, 11.1Gbps) optical interfaces

- Test end-to-end connectivity by Transmitting and Receiving OTN (Reed Soloman, 255/239) signals including a variety of client signals and PRBS test patterns
- Save time by simultaneously and independently testing 11.1Gb/s, 11.05Gb/s, 10.7Gb/s and 2.7Gb/s interfaces

Analyze and generate OTU, ODU and OPU overhead, errors and alarms

- Insert and analyze a variety of errors and alarms in network troubleshooting and equipment verification applications
- Test the Fault Type Fault Location (FTFL), section and path monitoring functions
- Ensure that signal degrade and signal fail thresholds on network elements and management systems are triggered appropriately
- Verify the network element interoperability with the TCM bytes

Transmit and Analyze correctable and uncorrectable FEC errors

- Verify a network element's ability to correct conditions through the use of FEC-enabled signals

Overhead
 -Mapping information
 -Payload type
 -Stuffing
 -TCM
 -APS

Client Signal
 -Protocol transparent
 -Backward compatible

Forward Error Correction
 -Implementation of FEC coding
 e.g. Reed-Solomon code

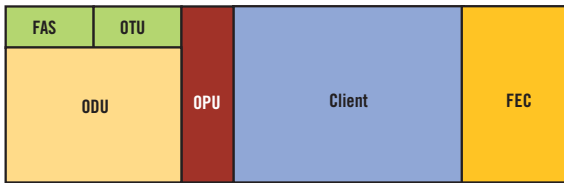

Framing A1	Framing A2	J0/Z0 Trace/Growth	Trace J1
BIP-8 B1	Orderwire E1	User F1	BIP-8 B3
Data Com D1	Data Com D2	Data Com D3	Signal Label C3
Pointer H1	Pointer H2	Pointer Action H3	Path Status G1
BIP-8 B2	APS K1	APS K2	User Channel F2
Data Com D4	Data Com D5	Data Com D6	Indicator H4
Data Com D7	Data Com D8	Data Com D9	Growth/DQDB Z3
Data Com D10	Data Com D11	Data Com D12	Growth Z4
Sync/Growth S1/Z1	FEBE/Growth M0/M1/Z2	Orderwire E2	Tandem Z5/N1

2.5G SONET/SDH Client

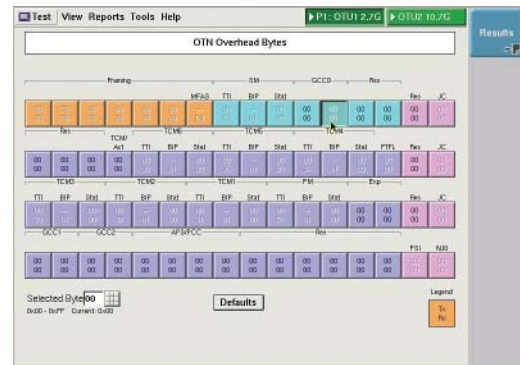

OTN overhead byte manipulation

Figure 5 OTN Frame

SONET/SDH

1.5M to 10G SONET/SDH BER testing

The Transport Module performs BER testing on all line interfaces in end-to-end or loopback applications, insert errors and alarms to verify network element conformance and connectivity, and measures bit error rates to ensure quality of service.

SONET/SDH overhead byte manipulation and analysis

Using the overhead byte manipulation and analysis capability of the T-BERD 8000 Transport Module, users can modify K1 and K2 bytes to test Automatic Protection Switching (APS): specify and identify user configurable path trace messages and payloads.

Service Disruption measurements

The Transport Module measures the protection switch times of SONET/SDH rings and their effects on tributaries. By measuring various error and alarm conditions on the tributaries, providers can verify that their transport network is providing adequate redundancy to guarantee SLAs.

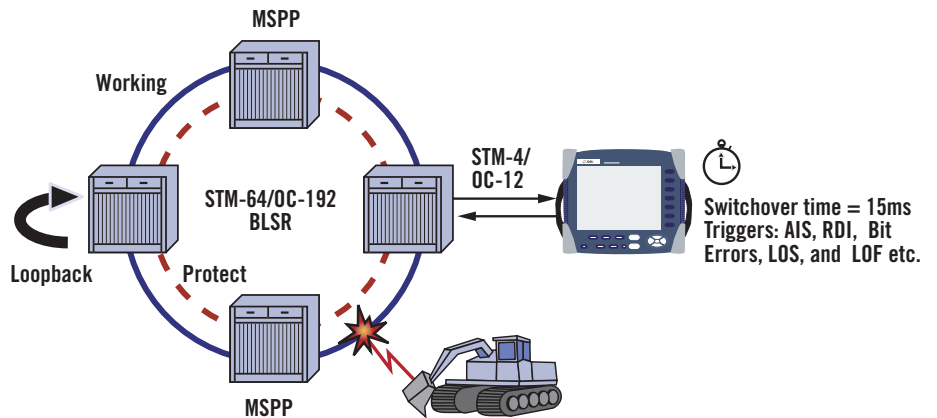

Figure 6 Service disruption

Jitter and Wander

As legacy and IP-based networks continue to converge, providers are seeing new technology deployments such as TDM over IP. These service offerings are creating new test needs that combine traditional Jitter/Wander and Packet-based testing for QoS. In addition, the emergence of low-cost small form factor pluggable (SFP) optics has increased the need to verify optical Jitter performance before service deployment. Based on established market leadership and design of the ANT and ONT's Jitter functionality, the flexibility of the Transport module allows users to combine both legacy and emerging test needs in support of today's services and network architectures.

O.172 / O.173 compliant Jitter & Wander testing

- Support T1, E1, T3, E3, E4, STS-1, STM-1e, 155M, 622M, 2.5G and 2.7G SONET/SDH, OTN Jitter and Wander generation and analysis
- For optical interfaces, support 35 milli UI accuracy for Jitter measurements

Ensure SONET/SDH network timing and synchronization

One of the most common SONET/SDH problems continues to be the synchronization of timing. If the timing of a network element or system is allowed to drift even slightly, it can have devastating affects on the network. The Transport Module Jitter and Wander test capability verifies the correct timing of network elements, systems and services.

Verify Jitter Transfer, Maximum Tolerable Jitter and Intrinsic Jitter performance

Users may verify system and network element performance by using the Transport Module's Automatic Measurement Sequences with stored and user definable Jitter masks. Ensuring that NE and system performance pass Jitter Transfer (JTF), Max Tolerable Jitter (MTJ) and Intrinsic Jitter metrics.

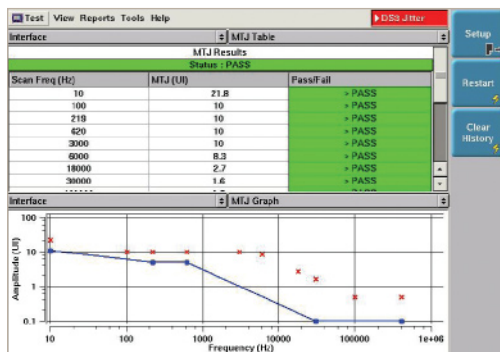

MTJ results

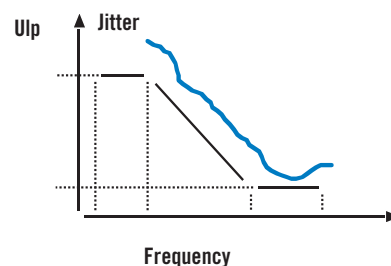

Figure 7 Jitter Mask

NewGen (Ethernet over SONET/SDH) testing

Using the NewGen module, support the efficient delivery of Ethernet services over the legacy SONET/SDH network. Test functionality includes:

- Support of optical 155M, 622M, 2.5G SDH and SONET Interfaces
- Higher Order and Lower Order VCAT (virtual concatenation) with up to 1G Ethernet traffic
- Virtual Concatenation Group search for lower order traffic
- GFP-F generation and analysis
- Differential delay analysis
- LCAS generation and analysis including protocol tracer
- Support of different Ethernet frames (DIX, 802.3, etc.)
- VLAN and QinQ generation and filter capability

This testing functionality from the Interface to the Ethernet analysis level is combined in a single, stand-alone unit making it the perfect tool for installing and troubleshooting circuits transporting Ethernet over SONET/SDH.

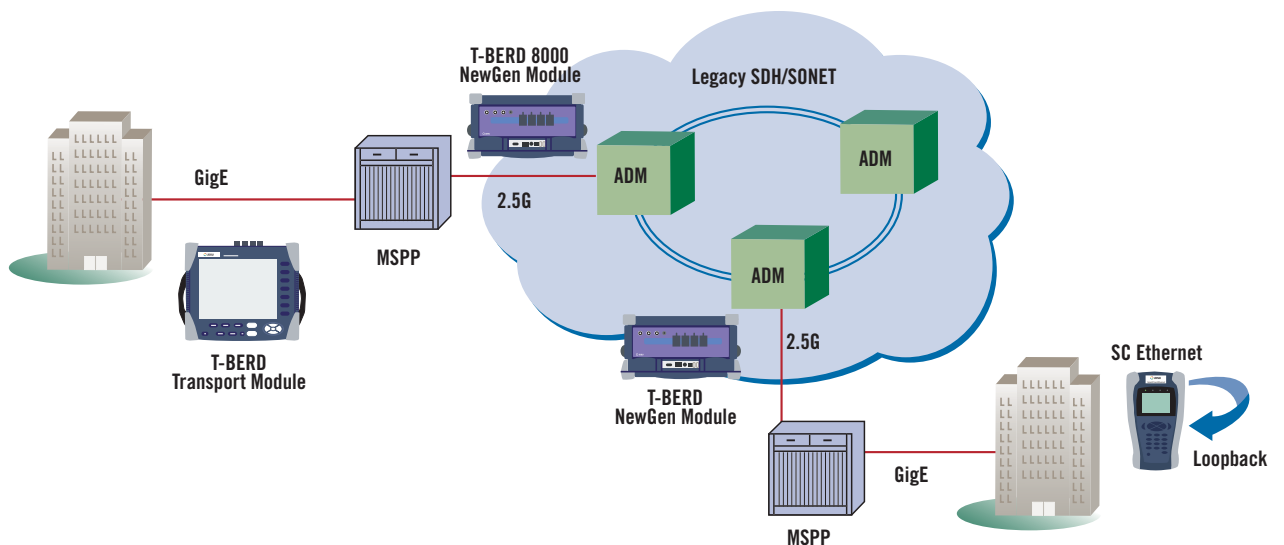

Figure 8 NewGen application

Fiber Optics

Faulty fibers and connectors continue to be the most common problems in today's Transport networks. Even the smallest issue with the fiber plant can adversely affect high speed transmission services. The T-BERD 8000 user interface module provides fiber test functionality without adding excess size or weight, eliminating the need to carry and manage separate test sets or additional modules. Never lose time due to faulty patch cords or optical connectors when turning up services

High Accuracy Power Meter and Source

Using the T-BERD 8000's stable power source and high accuracy power meter, users can measure power at any point of an active network, measure the insertion loss of a link between transmitter and receiver, and verify the loss characteristics of patch cords before turning up services. Providing this high accuracy loss test set eliminates the need for a separate handheld instruments or additional test modules.

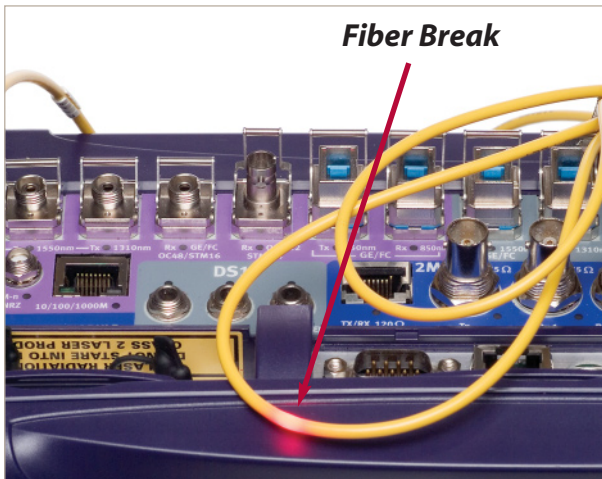

Visual fault locator

Visual Fault Locator

Considered a mandatory tool for any technician dealing with fiber patch cords, the built-in visible light source allows for quick fiber continuity checks and visual break locations.

Fiber Optic Microscope

Upon installation and maintenance of transmission systems, the optical inspection scope allows for the quality verification of the front optical connector during measurement or system turn-up. The use of the video probe allows for visualization of the connector in a safe environment, even if the fiber is active.

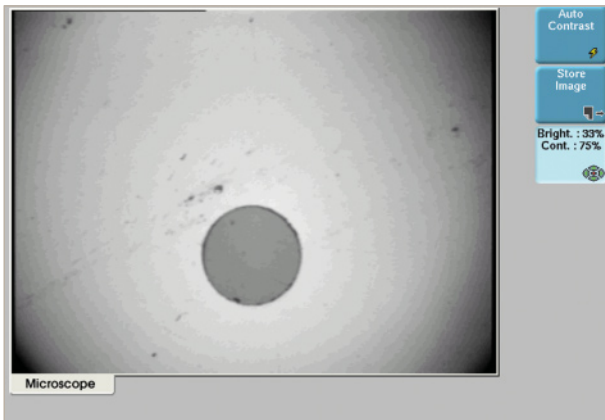

Connector surface inspection

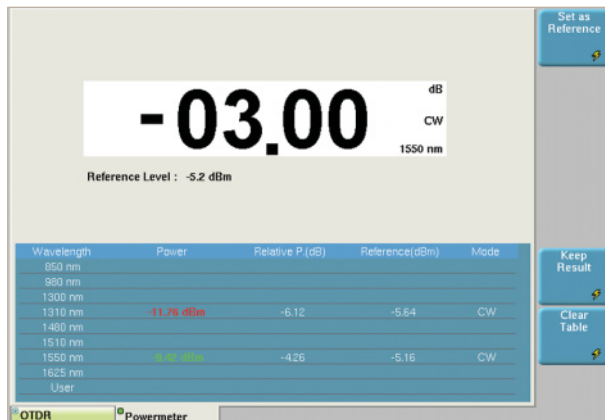

Jumper loss measurement

Physical Characteristics

Port Bank #1

- Includes 2.7Gb/s OTU-1, 2.5 Gb/s, 622 Mb/s and 155 Mb/s SONET/SDH Tx/Rx, GigE Tx/Rx and Fibre Channel (1G/2G) Tx/Rx at 850 nm, 1310 nm, and 1550 nm; and 10/100/1000 Mb/s Ethernet

Port Bank #2

- Includes 2.5 Gb/s, 622 Mb/s and 155 Mb/s SONET/SDH Tx/Rx, GigE Tx/Rx and Fibre Channel (1G/2G) Tx/Rx at 850 nm, 1310 nm and 1550 nm; and 10/100/1000 Mb/s Ethernet

10 Gb/s Port Bank

- 11.09, 11.05, 10.7 Gbps OTU-2, 10 Gb/s SONET/SDH and 10 GigE LAN/WAN Phy at 850 nm, 1310 nm and 1550 nm

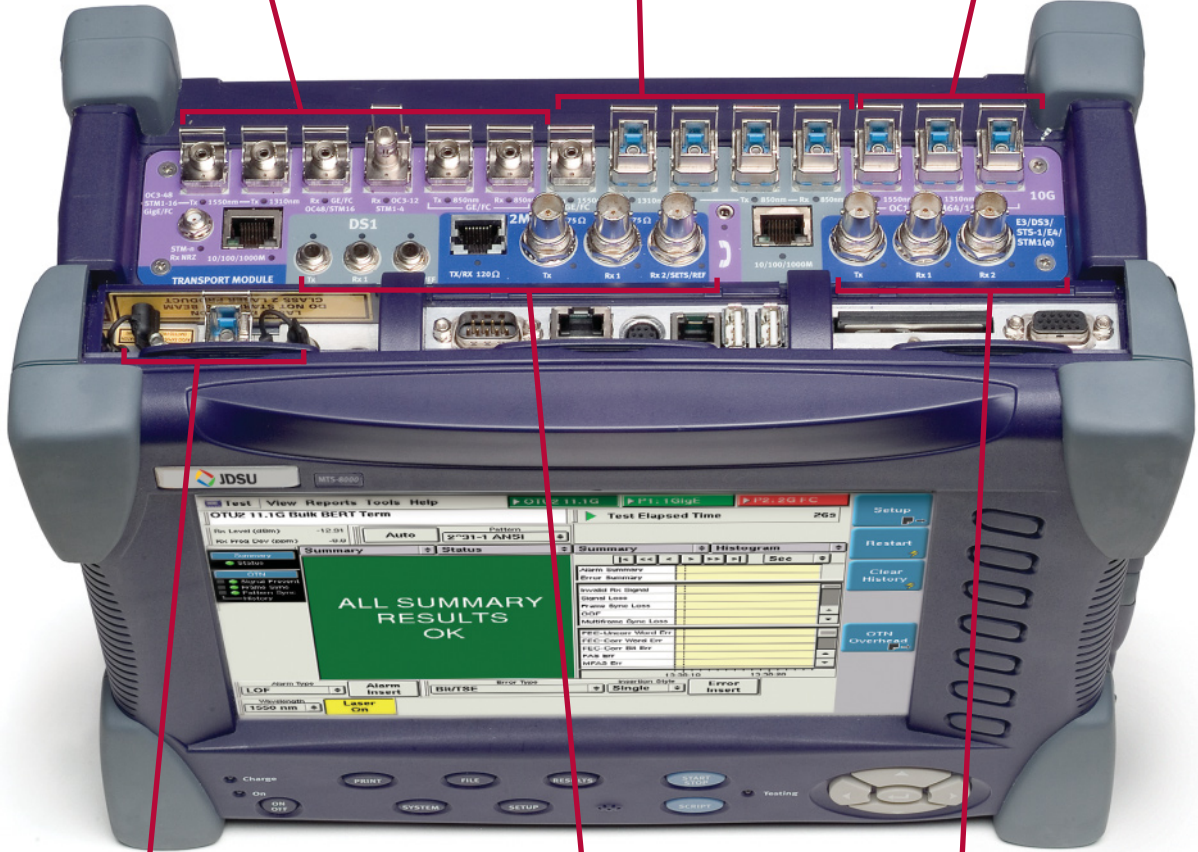

Optical Connection Check Interfaces

- High accuracy Power Meter
- Continuous Wave Power Source
- Visual Fault Locator

T1/E1 Port Bank

- T1 and E1 (balanced and unbalanced Tx/Rx

High Speed Electrical Port Bank

- E3, DS3, STS-1, E4, and STM-1 (e) Tx/Rx BNCs

All statements, technical information and recommendations related to the products herein are based upon information believed to be reliable or accurate. However, the accuracy or completeness thereof is not guaranteed, and no responsibility is assumed for any inaccuracies. The user assumes all risks and liability whatsoever in connection with the use of a product or its application. JDSU reserves the right to change at any time without notice the design, specifications, function, fit or form of its products described herein, including withdrawal at any time of a product offered for sale herein. JDSU makes no representations that the products herein are free from any intellectual property claims of others. Please contact JDSU for more information. JDSU and the JDSU logo are trademarks of JDS Uniphase Corporation. Other trademarks are the property of their respective holders. ©2007 JDS Uniphase Corporation. All rights reserved. 30137469 501 0807 TB8000BER.DS.ACC.TM.AE

Test & Measurement Regional Sales

NORTH AMERICA TEL: 1 866 228 3762 FAX: +1 301 353 9216	LATIN AMERICA TEL: +55 11 5503 3800 FAX: +55 11 5505 1598	ASIA PACIFIC TEL: +852 2892 0990 FAX: +852 2892 0770	EMEA TEL: +49 7121 86 2222 FAX: +49 7121 86 1222	WEBSITE: www.jdsu.com/test
---	--	---	---	---