

Operating and Service Guide

P-Series Wideband Power Sensor

N1921A and N1922A



Agilent Technologies

Manufacturing Part Number: N1920-90007

Printed in USA

February 2005

© Copyright Agilent Technologies Inc, 2005

Notices

No part of this manual may be reproduced in any form or by any means (including electronic storage and retrieval or translation into a foreign language) without prior agreement and written consent from Agilent Technologies, Inc. as governed by United States and international copyright laws.

Agilent Technologies, Inc.
1400 Fountaingrove Parkway
Santa Rosa, CA 95403

General Warranty

The material contained in this document is provided “as is,” and is subject to being changed, without notice, in future editions. Further, to the maximum extent permitted by applicable law, Agilent disclaims all warranties, either express or implied with regard to this manual and any information contained herein, including but not limited to the implied warranties of merchantability and fitness for a particular purpose. Agilent shall not be liable for errors or for incidental or consequential damages in connection with the furnishing, use, or performance of this document or any information contained herein. Should Agilent and the user have a separate written agreement with warranty terms covering the material in this document that conflict with these terms, the warranty terms in the separate agreement will control.

Certification

Agilent Technologies certifies that this product met its published specifications at the time of shipment from the factory. Agilent Technologies further certifies that its calibration measurements are traceable to the United States National Institute of Standards and Technology, to the extent allowed by the Institute’s calibration facility, and to the calibration facilities of other International Standards Organization members.

Safety Symbols

The following symbols on the instrument and in the documentation indicate precautions which must be taken to maintain safe operation of the instrument.



The Instruction Documentation Symbol. The product is marked with this symbol when it is necessary for the user to refer to the instructions in the supplied documentation.



ESD

This symbol indicates that a device, or part of a device, may be susceptible to electrostatic discharges (ESD) which can result in damage to the product. Observe ESD precautions given on the product, or its user documentation, when handling equipment bearing this mark.

**ISM GRP.1
CLASS A**

This is the symbol of an Industrial Scientific and Medical Group 1 Class A product.



The CE mark shows that the product complies with all relevant European Legal Directives.

ICES/NMB-001

This ISM device complies with Canadian ICES-001.

Cet appareil ISM est conforme à la norme NMB-001 du Canada.



N10149

The C-Tick mark is a registered trademark of the Australian Communications Authority. This signifies compliance with the Australian EMC Framework Regulations under the terms of the Radio Communications Act of 1992.

Safety Notices

This guide uses warnings and cautions to denote hazards

WARNING

A warning calls attention to a procedure, practice or the like, which, if not correctly performed or adhered to, could result in injury or loss of life. Do not proceed beyond a warning until the indicated conditions are fully understood and met.

CAUTION

A caution calls attention to a procedure, practice or the like which, if not correctly performed or adhered to, could result in damage to or the destruction of part or all of the equipment. Do not proceed beyond a caution until the indicated conditions are fully understood and met.

General Safety Information

The following general safety precautions must be observed during all phases of operation, service, and repair of this instrument. Failure to comply with these precautions or with specific warnings elsewhere in this manual violates safety standards of design, manufacture, and intended use of the instrument. Agilent Technologies assumes no liability for the customer's failure to comply with these requirements.

WARNING

BEFORE CONNECTING THE POWER SENSOR TO OTHER INSTRUMENTS ensure that all instruments are connected to the protective (earth) ground. Any interruption of the protective earth grounding will cause a potential shock hazard that could result in personal injury.

Sound Emission

Herstellerbescheinigung

Diese Information steht im Zusammenhang mit den Anforderungen der Maschinenlarminformationsverordnung vom 18 Januar 1991.

- Sound Pressure LpA < 70 dB.
- Am Arbeitsplatz.
- Normaler Betrieb.
- Nach DIN 45635 T. 19 (Typprüfung).

Manufacturers Declaration

This statement is provided to comply with the requirements of the German Sound DIN 45635 T. 19 (Typprüfung).

- Sound Pressure LpA < 70 dB.
- At operator position.
- Normal operation.
- According to ISO 7779 (Type Test).

1. Introduction

What You'll Find In This Chapter	2
General Information	3
Initial Inspection	3
Power Meter and Sensor Cable Requirements	4
Interconnections	4
Calibration	6
Overview of the P-Series Wideband Power Sensors	7
The Internal Zero and Calibration	7

2. Specifications and Characteristics

Introduction	10
Specification Definitions	10
Specifications	12
Frequency and Dynamic Power Range	12
Damage Level and RF Connector Type	12
Power Sensor Maximum SWR	13
Power Sensor Calibration Uncertainty	14
Physical Characteristics	15
Declaration of Conformity	16

3. Service

What You'll Find In This Chapter	18
General Information	19
Cleaning	19
Connector Cleaning	19
Performance Test	19
Agilent Sales and Service Offices	20

Contents

1 Introduction

What You'll Find In This Chapter

This Chapter introduces you to the P-Series Wideband Power Sensors. It contains the following sections:

- “General Information” on page 3.
- “Initial Inspection” on page 3.
- “Power Meter and Sensor Cable Requirements” on page 4.
- “Interconnections” on page 4.
- “Calibration” on page 6.
- “Overview of the P-Series Wideband Power Sensors” on page 7.

General Information

Welcome to the P-Series Wideband Power Sensors Operating and Service Guide. This guide contains information about the initial inspection, connection, and specifications of the P-Series Wideband Power Sensors. You can also find a copy of this guide on the Documentation CD-ROM supplied with the P-series power meters.

Figure 1-1 P-Series Wideband Power Sensors



To make best use of your sensor refer to the chapter “*Using P-Series Power Sensors*” in the *P-Series Power Meter User’s Guide*.

Initial Inspection

Inspect the shipping container for damage. If the shipping container or packaging material is damaged, it should be kept until the contents of the shipment have been checked mechanically and electrically. If there is mechanical damage, notify the nearest Agilent office. Keep the damaged shipping materials (if any) for inspection by the carrier and an Agilent representative. See “Agilent Sales and Service Offices” on page 20.

Power Meter and Sensor Cable Requirements

The P-Series Wideband Power Sensors are **ONLY** compatible with the P-Series Power Meters.

Table 1-1 lists the length of cable option, these have no interconnecting cable requirements, as the cable is permanently connected (hard-wired) to the P-Series Wideband power sensor.

Table 1-1

Cable Length Options

Option	Description
N1921A-105 N1922A-105	1.5m (5-ft) cable length
N1921A-106 N1922A-106	3m (10-ft) cable length
N1921A-107 N1922A-107	10m (31-ft) cable length

Interconnections

Connect the cable to the P-Series power meter's channel input. Figure 1-2 shows that you **must** align the red dot on the sensor's cable and the meter's connector.

WARNING

BEFORE CONNECTING THE POWER SENSOR TO OTHER INSTRUMENTS ensure that all instruments are connected to the protective (earth) ground. Any interruption of the protective earth grounding will cause a potential shock hazard that could result in personal injury.

Figure 1-2 **Connecting a Sensor Cable to a Power Meter**

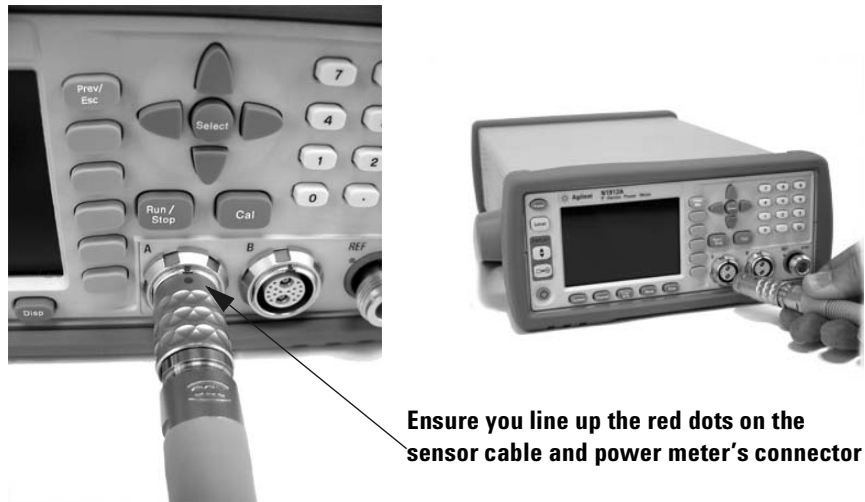

Allow a few seconds for the power meter to read the data contained in the power sensor's EEPROM.

NOTE

Ensure power sensor cables are attached and removed in an indoor environment.

Torque

Table 1-2 shows the connector type (for connection to DUT) for the power sensor models. A torque wrench must be used to tighten these connectors. Only use a wrench set to the correct torque value.

Table 1-2 **Wrench Size and Torque Values**

Model	Connector	Wrench Size	Torque Value
N1921A	Type-N (male)	3/4-inch open-end	12 in-lb (135 Ncm)
N1922A	2.4 mm (male)	5/16-inch open-end	8 in-lb (90 Ncm)

Calibration

When calibrating a P-Series Wideband Power Sensor, there is no need to disconnect it from the power source.

The power meter performs *Internal Zero* and Calibration routines. The process used for this *Internal Zero* and Calibration is explained in “Overview of the P-Series Wideband Power Sensors” on page 7.

The chapter “*Using P-Series Power Sensors*” in the *P-Series Power Meter User’s Guide* explains in more detail the methods used to perform the zero and calibration of the power sensor.

Overview of the P-Series Wideband Power Sensors

The P-Series Wideband Power Sensors has two different models.

- The N1921A has a frequency range of 50 MHz to 18 GHz.
- The N1922A has a frequency range of 50 MHz to 40 GHz.

The *Internal Zero* and Calibration

The P-Series Wideband Power Sensor's *Internal Zero* and Calibration process is used to combine the power sensor and power meter to make accurate power measurements.

Referring to Figure 1-3, Simplified Sensor Block Diagram, the process for the *Internal Zero* and Calibration explains how three objectives in this process are achieved.

Figure 1-3

Simplified Sensor Block Diagram

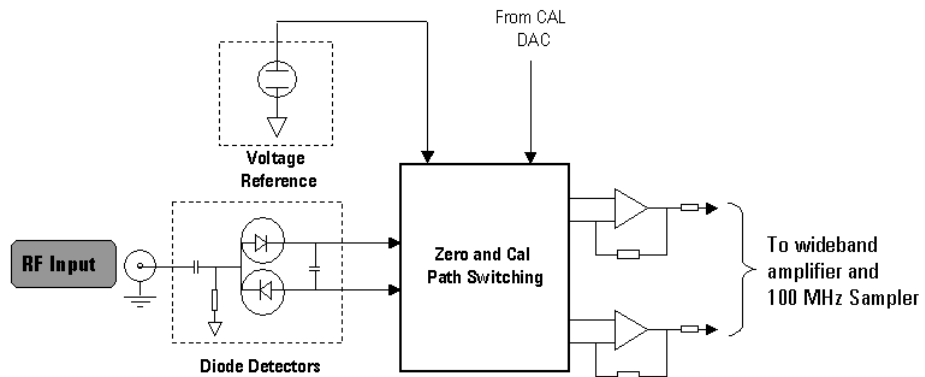

1. To account for the environment that the system is working in - the temperature and the presence of electromagnetic signals.

This is achieved during the *Internal Zero* process, where the Diode Detectors are isolated from the active amplifier circuitry. The process allows the zero measurement to be made, regardless of the RF input signal, thus allowing the sensor to remain connected to the DUT. The isolation is achieved by a network of transistor switches in the zero and calibration path switching.

Overview of the P-Series Wideband Power Sensors

2. To account for the combining of the sensor and meter, as these may never have been used together as a system.

This is achieved during the *Internal Calibration*, the Amplifier Circuitry is isolated from the Diode Detectors by a network of transistor switches and the sensor's voltage reference is routed to the Amplifier Circuitry.

3. To verify traceability to National Standards, hence, verifying your measurements are going to perform to specification.

To achieve traceable and accurate RF power measurements, each sensor is individually characterized during its production procedure. To achieve optimal accuracy, a 3-dimensional correction is generated across power, frequency and temperature. This uses advanced modeling techniques, and is superior in accuracy and speed of evaluation to the overlaying of linearity, temperature corrections and calibration factors.

As a *confidence check* of the connector integrity, the P-Series Wideband Power Sensor can be connected to any known good signal source (for example, the 50 MHz, 0 dBm reference) and a comparison made.

The calibration factors are stored in the EEPROM during the manufacturing process. All the compensation data is downloaded to the P-series power meter at power-on or when the power sensor is connected.

NOTE

Between 50 MHz and 500 MHz, the sensor is sensitive to the RF signal propagating through onto the Detector Amplifier Circuitry and resulting in distorted power measurements. To reduce this effect, additional filtering is switched into the measurement path, which results in a 15 MHz video bandwidth limitation for signals below 500 MHz.

2

Specifications and Characteristics

Introduction

The P-Series Wideband Power Sensors are designed for use with the P-Series power meters.

Specification Definitions

There are two types of product specifications:

- Warranted specifications
- Characteristic specifications

Warranted specifications

Warranted specifications are covered by the product warranty and apply over 0°C to 55°C, unless otherwise noted. Warranted specifications include Measurement Uncertainty calculated with 95% confidence.

Characteristic specifications

Characteristic specifications are not warranted. They describe product performance that is useful in the application of the power sensors by giving typical, but non-warranted performance parameters. These characteristics are shown in *italics* or denoted as “*typical*”, “*nominal*” or “*approximate*”.

Characteristic information is representative of the product. In many cases, it may also be supplemental to a warranted specification. Characteristic specifications are not verified on all power sensors. The types of characteristic specifications can be placed in two groups:

- The first group of characteristic types describes 'attributes' common to all products of a given model or option.

Examples of characteristics that describe 'attributes' are product weight, and 50 Ω input Type-N connector. In these examples product weight is an *approximate* value and a 50 Ω input is *nominal*. These two terms are most widely used when describing a product's 'attributes'.

- The second group of characteristic types describes 'statistically' the aggregate performance of the population of products.

These characteristics describe the expected behavior of the population of products. They do not guarantee the performance of any individual product. No measurement uncertainty value is accounted for in the specification. These specifications are referred to as *typical*.

Conditions

The power meter and sensor meet its specifications when:

- Stored for a minimum of two hours at a stable temperature within the operating temperature range, and turned on for at least 30 minutes.
- The power meter and power sensor are within their recommended calibration periods.
- Used in accordance to the information provided in the Power Meter's User's Guide.

Specifications

Frequency and Dynamic Power Range

Table 2-1 Frequency and Dynamic Power Range

Sensor Model	Frequency Range	Dynamic Power Range
N1921A	50 MHz to 18 GHz	-35 dBm to +20 dBm (>500 MHz) -30 dBm to +20 dBm (50 MHz - 500 MHz)
N1922A	50 MHz to 40 GHz	-35 dBm to +20 dBm (>500 MHz) -30 dBm to +20 dBm (50 MHz - 500 MHz)

Damage Level and RF Connector Type

Table 2-2 Damage Level and RF Connector Type

Sensor Model	Damage Level (Average Power)	Damage Level (Peak Power)	RF Connector Type
N1921A	+23 dBm	+30 dBm, <1 μ s duration	Type-N (m)
N1922A	+23 dBm	+30 dBm, <1 μ s duration	2.4 mm (m)

Power Sensor Maximum SWR

Table 2-3

Power Sensor Maximum SWR

Sensor Model	Frequency Band	Maximum SWR
N1921A	50.0 MHz to 10.0 GHz:	1.2
	10.0 GHz to 18.0 GHz:	1.26
N1922A	50.0 MHz to 10.0 GHz:	1.2
	10.0 GHz to 18.0 GHz:	1.26
	18.0 GHz to 26.5 GHz:	1.3
	26.5 GHz to 40.0 GHz:	1.5

Power Sensor Calibration Uncertainty

Definition: Uncertainty resulting from non-linearity in the sensor detection and correction process. This can be considered as a combination of traditional linearity, calibration factor, temperature specifications and the uncertainty associated with the internal calibration process.

Table 2-4

Power Sensor Calibration Uncertainty

Sensor Model	Frequency Band	Calibration Uncertainty^a
N1921A	50.0 MHz to 500.0 MHz	4.5%
	500.0 MHz to 1.0 GHz:	4.0%
	1.0 GHz to 10.0 GHz	4.0%
	10.0 GHz to 18.0 GHz	5.0%
N1922A	50.0 MHz to 500.0 MHz	4.3%
	500.0 MHz to 1.0 GHz:	4.2%
	1.0 GHz to 10.0 GHz	4.4%
	10.0 GHz to 18.0 GHz	4.7%
	18.0 GHz to 26.5 GHz:	5.9%
	26.5 GHz to 40.0 GHz:	6.0%

a. In humidity greater than 70%, an additional 0.6% should be added to these values.

Physical Characteristics

Table 2-5 Physical Dimensions

Sensor Model	Dimensions
N1921A	<i>Length: 135 mm (5.3 in)</i>
	<i>Width: 40 mm (1.6 in)</i>
	<i>Height: 27 mm (1.1 in)</i>
N1922A	<i>Length: 127 mm (5.0 in)</i>
	<i>Width: 40 mm (1.6 in)</i>
	<i>Height: 27 mm (1.1 in)</i>

Table 2-6 Sensor Cable Lengths and Weights

Option	Length	Weight with cable
Option 105 (standard)	<i>1.5 m (5-feet)</i>	<i>0.4 kg (0.88 lb)</i>
Option 106	<i>3.0 m (10-feet)</i>	<i>0.6 kg (1.32 lb)</i>
Option 107	<i>10 m (31-feet)</i>	<i>1.4 kg (3.01 lb)</i>

Declaration of Conformity

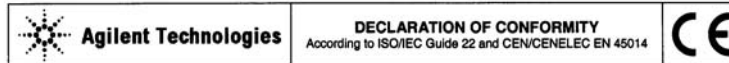

Manufacturer's Name: Agilent Technologies, Inc.
Manufacturer's Address: 1400 Fountaingrove Parkway
Supplier's Address: Santa Rosa, California 95403-1799
USA

Declares under sole responsibility that the product as originally delivered

Product Name: P-Series Wideband Power Sensor
Model Number: N1921A, N1922A
Product Options: This declaration covers all options of the above product(s)

complies with the essential requirements of the following applicable European Directives, and carries the CE marking accordingly:

- The EMC Directive 89/336/EEC, amended by 93/68/EEC

and conforms with the following product standards:

EMC	Standard	Limit
	IEC 61326:1997+A1:1998/ EN 61326:1997+A1:1998	
	Reference standards	
	CISPR 11:1997+A1:1999/ EN 55011:1998+A1:1999	Group 1 Class A
	IEC 61000-4-2:1995+A1:1998 / EN 61000-4-2:1995	4 kV CD, 8 kV AD
	IEC 61000-4-3:1995 / EN 61000-4-3:1995	3 V/m, 80-1000 MHz
	IEC 61000-4-4:1995 / EN 61000-4-4:1995	0.5 kV signal lines, 1 kV power lines
	IEC 61000-4-5:1995 / EN 61000-4-5:1995	0.5 kV line-line, 1 kV line-ground
	IEC 61000-4-6:1996 / EN 61000-4-6:1996	3 V, 0.15-80 MHz
	IEC 61000-4-11:1994 / EN 61000-4-11:1994	1 cycle, 100%

Canada: ICES-001:1998
Australia/New Zealand: AS/NZS 2064.1

The product was tested in a typical configuration with Agilent Technologies test systems.

Supplementary Information:

A safety evaluation was not required for this product because its input power was below the requirements specified in the Low Voltage Directive 73/23/EEC, amended by 93/68/EEC.

This DoC applies to above-listed products placed on the EU market after:

4 February 2005
Date

Paul Forrest
Paul Forrest
Quality Engineering Manager

For further information, please contact your local Agilent Technologies sales office, agent or distributor, or Agilent Technologies Deutschland GmbH, Herrenberger Straße 130, D 71034 Böblingen, Germany.

3**Service**

What You'll Find In This Chapter

This Chapter introduces you to the P-Series Wideband Power Sensors. It contains the following sections:

- “General Information” on page 19.
- “Agilent Sales and Service Offices” on page 20.

General Information

This chapter contains information about general maintenance, performance tests, troubleshooting and repair of the P-Series Wideband Power Sensors.

Cleaning

Use a clean, damp cloth to clean the body of the P-Series Wideband Power Sensor.

Connector Cleaning

The RF connector beads deteriorate when contacted by hydrocarbon compounds such as acetone, trichloroethylene, carbon tetrachloride, and benzene.

Clean the connector only at a static free workstation. Electrostatic discharge to the center pin of the connector will render the power sensor inoperative.

Keeping in mind its flammable nature; a solution of pure isopropyl or ethyl alcohol can be used to clean the connector.

Clean the connector face using a cotton swab dipped in isopropyl alcohol. If the swab is too big use a round wooden toothpick wrapped in a lint free cotton cloth dipped in isopropyl alcohol.

Performance Test

The Performance and Calibration Tests require the sensor to be returned to the factory.

To arrange this contact the service centre. See “Agilent Sales and Service Offices” on page 20 for this information.

Repair of Defective Sensor

There are no serviceable parts inside the P-Series Wideband Power Sensors. If the sensor is defective, it needs to be returned to an Agilent service center.

Agilent Sales and Service Offices

In any correspondence or telephone conversations, refer to the power meter by its model number and full serial number. With this information, the Agilent representative can quickly determine whether your unit is still within its warranty period.

UNITED STATES	Agilent Technologies (tel) 1 800 829 4444
CANADA	Agilent Technologies Canada Inc. Test & Measurement (tel) 1 877 894 4414
EUROPE	Agilent Technologies Test & Measurement European Marketing Organization (tel) (31 20) 547 2000
JAPAN	Agilent Technologies Japan Ltd. (tel) (81) 426 56 7832 (fax) (81) 426 56 7840
LATIN AMERICA	Agilent Technologies Latin America Region Headquarters, USA (tel) (305) 267 4245 (fax) (305) 267 4286
AUSTRALIA and NEW ZEALAND	Agilent Technologies Australia Pty Ltd. (tel) 1-800 629 4852 (Australia) (fax) (61 3) 9272 0749 (Australia) (tel) 0-800 738 378 (New Zealand) (fax) (64 4) 802 6881 (New Zealand)
ASIA PACIFIC	Agilent Technologies, Hong Kong (tel) (852) 3197 7777 (fax) (852) 2506 9284

You can visit our website: - <http://www.agilent.com/find/assist>.