

Keysight Technologies 85058B/E 1.85 mm Calibration Kits

NOTICE: This document contains references to Agilent Technologies. Agilent's former Test and Measurement business has become Keysight Technologies. For more information, go to www.keysight.com.



Documentation Warranty

THE MATERIAL CONTAINED IN THIS DOCUMENT IS PROVIDED “AS IS,” AND IS SUBJECT TO BEING CHANGED, WITHOUT NOTICE, IN FUTURE EDITIONS. FURTHER, TO THE MAXIMUM EXTENT PERMITTED BY APPLICABLE LAW, KEYSIGHT DISCLAIMS ALL WARRANTIES, EITHER EXPRESS OR IMPLIED WITH REGARD TO THIS MANUAL AND ANY INFORMATION CONTAINED HEREIN, INCLUDING BUT NOT LIMITED TO THE IMPLIED WARRANTIES OF MERCHANTABILITY AND FITNESS FOR A PARTICULAR PURPOSE. KEYSIGHT SHALL NOT BE LIABLE FOR ERRORS OR FOR INCIDENTAL OR CONSEQUENTIAL DAMAGES IN CONNECTION WITH THE FURNISHING, USE, OR PERFORMANCE OF THIS DOCUMENT OR ANY INFORMATION CONTAINED HEREIN. SHOULD KEYSIGHT AND THE USER HAVE A SEPARATE WRITTEN AGREEMENT WITH WARRANTY TERMS COVERING THE MATERIAL IN THIS DOCUMENT THAT CONFLICT WITH THESE TERMS, THE WARRANTY TERMS IN THE SEPARATE AGREEMENT WILL CONTROL.

DFARS/Restricted Rights Notice

If software is for use in the performance of a U.S. Government prime contract or subcontract, Software is delivered and licensed as “Commercial computer software” as defined in DFAR 252.227-7014 (June 1995), or as a “commercial item” as defined in FAR 2.101(a) or as “Restricted computer software” as defined in FAR 52.227-19 (June 1987) or any equivalent agency regulation or contract clause. Use, duplication or disclosure of Software is subject to Keysight Technologies’ standard commercial license terms, and non-DOD Departments and Agencies of the U.S. Government will receive no greater than Restricted Rights as defined in FAR 52.227-19(c)(1-2) (June 1987). U.S. Government users will receive no greater than Limited Rights as defined in FAR 52.227-14 (June 1987) or DFAR 252.227-7015 (b)(2) (November 1995), as applicable in any technical data.

Assistance

Product maintenance agreements and other customer assistance agreements are available for Keysight products.

For any assistance, contact Keysight Technologies. Refer to “Contacting Keysight” on page 5.

Printing Copies of Documentation from the Web

To print copies of documentation from the Web, download the PDF file from the Keysight web site:

- Go to www.keysight.com.
- Enter the document's part number (located on the title page) in the Search box.
- Click **Search**.
- Click on the hyperlink for the document.
- Click the printer icon located in the tool bar.

Contents

1 General Information

Calibration Kit Overview	1-2
Two Models for Defining Calibration Standards	1-2
1.85 mm Calibration Techniques	1-3
85058B (Standard) Kit Contents	1-4
85058E (Economy) Kit Contents	1-5
Calibration Definitions	1-6
Equipment Required but Not Supplied	1-6
Achieving Specified Frequency Performance	1-7
Offset-Short Calibration Using the 85058B (Standard) Calibration Kit	1-7
Broadband SOLT Calibration Using the 85058E (Economy) Calibration Kit	1-8
Network Analyzer Calibrations	1-9
Calibration Residual Error Specifications	1-13
Incoming Inspection	1-16
Recording the Device Serial Numbers	1-17
Slotted Connectors	1-19
Clarifying the Terminology of a Connector Interface	1-20
Preventive Maintenance	1-20
When to Calibrate	1-21

2 Specifications

Environmental Requirements	2-2
Temperature—What to Watch Out For	2-2
Mechanical Characteristics	2-3
Pin Depth	2-3
Electrical Specifications	2-4
Certification	2-9

3 Use, Maintenance, and Care of the Devices

Electrostatic Discharge	3-2
Visual Inspection	3-3
Look for Obvious Defects and Damage First	3-3
Connector Contacts	3-3
Concentricity	3-4
Inspect the Mating Plane Surfaces	3-5
Inspect Female Connectors	3-5
Cleaning Connectors	3-6
Gaging Connectors	3-8
Connector Gage Accuracy	3-8
When to Gage Connectors	3-9
Gaging Procedures	3-10
Connections	3-14
How to Make a Connection	3-14
How to Separate a Connection	3-16
Handling and Storage	3-16

4 Performance Verification

Introduction	4-2
------------------------	-----

Contents

How Keysight Verifies the Devices in This Kit	4-2
Recertification	4-3
How Often to Recertify.	4-3
Where to Send a Kit for Recertification	4-3
5 Troubleshooting	
Troubleshooting Process.	5-2
Where to Look for More Information	5-3
Returning a Kit or Device to Keysight	5-4
Contacting Keysight	5-5
6 Replaceable Parts	
Introduction	6-2
A Standard Definitions	
Class Assignments and Standard Definitions Values are Available on the Web.	A-2

1 General Information

Calibration Kit Overview

The Keysight 85058B (Standard) and 85058E (Economy) 1.85 mm calibration kits are used to calibrate Keysight network analyzers up to 67 GHz for measurements of components with 1.85 mm connectors. The 1.85 mm connector is designed such that it may be mated with 2.4 mm connectors.

The 85058B (Standard) is the more accurate of the two calibration kits, containing twelve calibration standards. The 85058E (Economy) kit is less accurate, containing six calibration standards.

The standards in these calibration kits allow you to perform simple 1- or 2-port and TRM (thru-reflect-match) calibrations.

Two Models for Defining Calibration Standards

The 85058 family of calibration kits offers the following two models for defining calibration standards:

- Data-based model
 - ❑ PNA: 85058B and 85058E
- Polynomial model
 - ❑ PNA: 85058BP and the 85058EP

The PNA family of analyzers offers both the data-based models and the polynomial models as cal kit selections.

Data-Based Model

The data-based model (85058B or 85058E) of each calibration kit provides higher accuracy for describing calibration standards than the polynomial model (85058BP or 85058EP). The data-based nominal S-Parameter model for each calibration standard is generated by using a theoretical derivation or a high accuracy S-Parameter measurement. These nominal S-parameter models are stored as part of the data-based model. Errors that can be the result of polynomial model approximations do not exist.

The data-based models may only be used with the SmartCal (Guided) Calibration method of the Cal Wizard. Using the data-based models with the Unguided Calibration method of the Cal Wizard is not allowed.

The data-based models may NOT be edited with the Advanced Modify Cal Kit dialog box. Attempts to programmatically edit the definitions of the data-based-model calibration standards will result in reported errors (i.e. SCPI Execution Error).

In the PNA's Modify Calibration Class Assignments dialog box¹, the "Expanded Math" feature is turned ON by default when the 85058B data-based model is selected from a cal kit menu. In order to achieve a more accurate calibration, Expanded Math uses the data at any given

1. Pathway to the Modify Calibration Class Assignments dialog box: Calibration > Advanced Modify Cal Kit > Edit Kit > Class Assignments: Edit.

frequency from ALL measured standards instead of using only the three standards specified in the class definitions. If you are using a PNA, it is RECOMMENDED that you use Expanded Math with the 85058B data-based model for the highest accuracy. Expanded Math has no effect with the 85058E data-based model.

Polynomial Model

The polynomial models may be used with SmartCal (Guided) and the Unguided Mechanical Calibration method of the PNA Cal Wizard. Polynomial models are less accurate than the data-based models. The polynomial models define the calibration standards with traditional four-term polynomial calibration standard modeling parameters. For the PNA, it is NOT RECOMMENDED that the polynomial models be used if the most accurate results are desired.

If you're calibrating over the full frequency range of the calibration kit, you may be prompted to connect some calibration standards more than once. These standards are defined by using multiple polynomial models to achieve the full frequency range of operation.

Unlike the data-based models, the polynomial models allow you to modify the definitions of calibration standards like any other traditional model-based calibration kit. This is accomplished with the Advanced Modify Cal Kit dialog box. For more information on modifying the definitions of the calibration standards, refer to online PNA Help.

In the Modify Class Assignments dialog box, the "Expanded Math" feature is turned OFF by default when a polynomial model is selected. It is NOT RECOMMENDED that you use Expanded Math with a polynomial model unless the calibration kit includes overlapped banded standards such as a sliding load.

Accuracy Ranking of the 1.85 mm Calibration Kits (item #1 has highest accuracy)

1. 85058B (Standard), data-based mode
2. 85058BP (Standard), polynomial model
3. 85058E (Economy), data-based model
4. 85058EP (Economy), polynomial model

1.85 mm Calibration Techniques

85058B (Standard) Calibration Kit

- Offset Short Calibration technique
 - Files:
 - 85058B Data-Based.ckt
 - 85058BP Polynomial.ckt
 - OSL/SSS
 - "Lowband" definition of lowband load, open, and Short 1

85058E (Economy) Calibration Kit

- Broadband Load Calibration technique
 - Files:

Calibration Kit Overview

85058E Data-Based.ckt
85058EP Polynomial.ckt

- OSL
- “Broadband” definition of broadband termination, open, and Short 1

85058B (Standard) Kit Contents

The **85058B (Standard)** calibration kit contains the following:

- one pair (male and female) of an offset open
- one pair (male and female) of a lowband load
- four pairs (male and female) of offset shorts
- three adapters
- a 5/16 inch, 90 N–cm (8 in–lb) torque wrench for use on the 1.85 mm connectors
- an open–end wrench for the 8mm flats on some of the components
- two gage sets
- a 10x magnifying glass

Refer to [Table 6-1 on page 6-3](#) and [Figure 6-1 on page 6-5](#) for a complete list of kit contents and their associated part numbers.

Lowband Loads

The best operating region of the load is from DC to 35 GHz. Performance degrades quickly above 35 GHz.

Offset Opens and Shorts

The offset opens and shorts are built from parts that are machined to the current state-of-the-art in precision machining. The offset short’s inner conductors have a one-piece construction, common with the shorting plane. This construction provides for extremely repeatable connections. The offset opens have inner conductors that are supported by a strong, low-dielectric plastic to provide repeatability and reliability. Both the opens and shorts are constructed so that the pin depth can be controlled very tightly, thereby minimizing phase errors. The length of the offset opens is designed so that the difference in phase of their reflection coefficients is approximately 180 degrees at all frequencies, with respect to offset Short 1.

Different combinations of offset shorts using three different lengths are used to calibrate frequency ranges from 35 to 50 GHz and from 50 to 67 GHz. The calibration coefficients for these offset shorts are optimized for their applicable bandwidths.

How to Identify Devices The shorts, opens, and loads in the kit are identified by the number of rings (or bands) around the body of the device.

- lowband loads have no rings or bands
- 5.4 mm offset short has 1 ring or band and is identified as Short 1

- 6.3 mm offset short has 2 rings or bands and is identified as Short 2
- 7.12 mm offset short has 3 rings or bands and is identified as Short 3
- 7.6 mm offset short has 4 rings or bands and is identified as Short 4
- offset open has 1 ring and is designed to be 180 degrees out of phase with Short 1. In addition, the offset open has a rounded edge to help distinguish it from the shorts (see [Figure 1-1](#)).

Figure 1-1 OPEN Calibration Devices: 85058B and 85058E

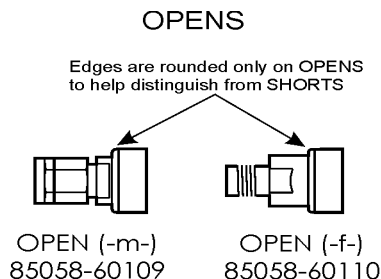

Adapters

Like the other devices in the kit, the adapters are built to very tight tolerances to provide good broadband performance and to ensure stable, repeatable connections.

85058E (Economy) Kit Contents

The 85058E (Economy) calibration kit contains the following:

- one pair (male and female) of an offset open, offset short, and a broadband termination
- three adapters
- a 5/16 inch, 90 N-cm (8 in-lb) torque wrench for use on the 1.85 mm connectors
- an open-end wrench for the 8 mm flats on some of the components

Refer to [Table 6-1 on page 6-3](#) and [Figure 6-2 on page 6-7](#) for a complete list of kit contents and their associated part numbers.

Broadband Terminations

The broadband terminations are instrument-grade, 50 Ω terminations that have been optimized for performance up to 67 GHz. The rugged internal structure provides for highly repeatable connections. A distributed resistive element on sapphire provides excellent stability and return loss. The smooth body of the broadband termination allows it to be easily distinguished from an open and short.

Offset Opens and Shorts

The opens and shorts are built from parts that are machined to the current state-of-the-art precision machining.

The short's inner conductors have a one-piece construction, common with the shorting plane.

Calibration Kit Overview

This construction provides for extremely repeatable connections.

The offset opens have inner conductors that are supported by a strong, low-dielectric plastic to provide repeatability and reliability.

Both the opens and shorts are constructed so that the pin depth can be controlled very tightly, thereby minimizing phase errors. The opens and shorts have offsets. The lengths of these offsets are designed so that the difference in phase of their reflection coefficients is approximately 180 degrees at all frequencies. The open has a rounded edge to help distinguish it from the shorts (see [Figure 1-1 on page 1-5](#)).

Adapters

Like the other devices in the kit, the adapters are built to very tight tolerances to provide good broadband performance and to ensure stable, repeatable connections.

Calibration Definitions

The calibration kit must be selected prior to performing a calibration. In addition, the calibration definitions for the devices in the kit must be installed in the analyzer if not permanently stored in the internal memory or hard drive.

The calibration definitions can be:

- recalled from the analyzer (if stored in internal memory or the hard drive)
- entered from the front panel (polynomial models only)

Class assignments and standard definitions may change as more accurate model and calibration methods are developed. You can download the most recent class assignments and standard definitions from Keysight's Calibration Kit Definitions Web page at <http://na.support.keysight.com/pna/caldefs/stddefs.html>.

Refer to online PNA Help for instructions on selecting the calibration kit, installing (if necessary) the calibration definitions, and performing a calibration.

NOTE The 8510 network analyzer is no longer being sold or supported by Keysight. However, you can download the 8510 class assignments and standard definitions from Keysight's Calibration Kit Definitions Web page at <http://na.support.keysight.com/pna/caldefs/stddefs.html>

Equipment Required but Not Supplied

Gage sets (not provided with the 85058E), adapters, ESD protection devices, and various connector cleaning supplies are *not* included in the calibration kit but are required to ensure successful operation of the calibration kit. Refer to [Table 6-3 on page 6-8](#) for ordering information.

Achieving Specified Frequency Performance

The standards in this calibration kit allow you to perform 1- or 2-port and TRM (thru-reflect-match) calibrations.

NOTE For best results, before beginning calibration refer to “Clarifying the Terminology of a Connector Interface” on page 1-20.

Offset-Short Calibration Using the 85058B (Standard) Calibration Kit

Table 1-1 Offset-Short Calibration Standards

Calibration Kit Label: PNA: 85058B Data-Based 85058BP Polynomial <hr/> PNA File Names: 85058B Data-Based.ckt 85058BP Polynomial.ckt						
Frequency Range	Calibration Technique	“Open” Standard (Reflection)	“Short” Standard (Reflection)	“Load” Standard (Reflection)	“Thru” Standard (not used for 1–port)	“Isolation” Standard ^a
DC–35	SOLT ^b	Open	Short 1	Load LB	Thru	Load BB ^c
35–50 GHz	Offset	Short 2	Short 1	Short 4	Thru	Load BB ^c
50–67 GHz	Offset	Short 3	Short 1	Short 4	Thru	Load BB ^c
To Combine Frequency Ranges ^d						
DC–35 GHz						
	SOLT ^b and Offset	Open	Short 1	Load LB	Thru	Load BB ^c
35–67 GHz						
	Offset	Short 2	Short 1	Short 4 Short 2	Thru	Load BB ^c
DC–67 GHz						
	SOLT ^b and Offset	Open Short 3	Short 3 Short 1	Load LB Short 4 Short 2	Thru	Load BB ^c

- a. For best measurement results, the isolation standard should be the equivalent impedance of the DUT.
- b. SOLT = Short, Open, Load and Thru standards
- c. Load BB is the lowband load using a broadband load definition.
- d. Combinations of the calibration methods shown in the upper half of Table 1-1 are used to calibrate over the frequency ranges shown in the lower half of the table.

Achieving Specified Frequency Performance

Broadband SOLT Calibration Using the 85058E (Economy) Calibration Kit

The Broadband SOLT calibration is the only calibration technique available with the 85058E (Economy) kit. You can calibrate from DC to 67 GHz using the standards in [Table 1-2](#).

Table 1-2 85058E (Economy) Broadband SOLT^a Calibration Standards

Calibration Kit Label: PNA: 85058E Data-Based 85058EP Polynomial <hr/> PNA File Names: 85058E Data-Based.ckt 85058EP Polynomial.ckt						
Frequency Range	Calibration Technique	“Open” Standard	“Short” Standard	“Load” Standard	“Thru” Standard (not used for 1–port cal)	“Isolation” Standard
DC–67 GHz	SOLT	Open (broadband)	Short 1 (broadband)	Load BB (broadband)	Thru	Load BB

a. SOLT = Short, Open, Load and Thru standards

Network Analyzer Calibrations

To calibrate a Network Analyzer, use the following combinations of standards listed in [Table 1-3](#) and [Table 1-4](#) (for 1-port calibrations), and [Table 1-5](#) and [Table 1-6](#) (for 2-port calibrations) for the best results. For more information, refer to [Table 1-1 on page 1-7](#) and [Table 1-2 on page 1-8](#).

Table 1-3 85058B (Standard) 1-Port Calibration

Frequency Range	Calibration Type	Calibration Standards	Standard Numbers ^a
PNA File Names: 85058B Data-Based.ckt 85058BP Polynomial.ckt			
DC to 35 Ghz	Open	Open	2, 4
	Short	Short 1	1, 3
	Load	Load	9, 24
35 to 50 GHz	Offset Short	Short 1	12, 16
	Offset Short	Short 2	13, 17
	Offset Short	Short 4	15, 19
50 to 67 GHz	Offset Short	Short 1	12, 16
	Offset Short	Short 2	13, 17
	Offset Short	Short 3	14, 18

a. Standard numbers reference the line numbers in the Standard Definitions tables, located in the Appendix.

General Information
Network Analyzer Calibrations

Table 1-4 85058E (Economy) 1-Port Calibration

Frequency Range	Calibration Type	Calibration Standards	Standard Numbers ^a
PNA File Names: 85058E Data-Based.ckt 85058EP Polynomial.ckt			
DC to 67 GHz	Open	Open	2, 4
	Short	Short 1	1, 3
	Load	Termination (broadband)	9, 24

a. Standard numbers reference the line numbers in the Standard Definitions tables located in the Appendix.

Table 1-5 85058B (Standard) 2-Port Calibration^a

Frequency Range	Calibration Type	Calibration Standards	Standard Numbers
PNA File Names: 85058B Data-Based.ckt 85058BP Polynomial.ckt			
DC to 35 GHz	Open	Open	2, 4
	Short	Short 1	1, 3
	Load	Load	9, 24
	Thru	Thru	11
35 to 50 GHz	Offset Short	Short 1	12, 16
	Offset Short	Short 2	13, 17
	Offset Short	Short 4	15, 19
	Thru	Thru	11
50 to 67 GHz	Offset Short	Short 1	12, 16
	Offset Short	Short 2	13, 17
	Offset Short	Short 3	14, 18
	Thru	Thru	11
DC to 67 GHz	Thru	Thru	11
	Reflect	Short 1	5, 7
	Match	Load	10 ^b , 22 ^b

a. Standard numbers reference the line numbers in the Standard Definitions tables, located in the Appendix.

b. Polynomial-model only (85058BP).

General Information
Network Analyzer Calibrations

Table 1-6 85058E (Economy) 2-Port Calibration^a

Frequency Range	Calibration Type	Calibration Standards	Standard Numbers
PNA File Names: 85058E Data-Based.ckt 85058EP Polynomial.ckt			
DC to 67 GHz	Open	Open	2, 4
	Short	Short 3	1, 3
	Load	Termination (broadband)	9, 24
	Thru	Thru	11
DC to 67 GHz	Thru	Thru	11
	Reflect	Short 1	1, 3
	Match	Termination (broadband)	9, 24

a. Standard numbers reference the line numbers in the Standard Definitions tables, located in the Appendix.

Calibration Residual Error Specifications

Please download our free Vector Network Analyzer Uncertainty Calculator from http://www.keysight.com/find/na_calculator.

Table 1-7 85058B (Standard) Residual System Calibration Error Specifications

Parameter	Cal Method ^a	Frequency Range	Residuals		
			PNA ^b		PNA ^c
			Data-Based Model ^d Expanded Math Selected	Data-Based Model ^d Expanded Math Unselected	Polynomial Model ^d Expanded Math Unselected
Directivity	OSL	DC to 2 GHz	35	35	35
	OSL	2 to 10 GHz	41	35	35
	OSL	10 to 20 GHz	38	35	35
	OSL	20 to 35 GHz	37	30	30
	SSS	35 to 50 GHz	37	36	33
	SSS	50 to 67 GHz	34	34	31
Source Match	OSL	DC to 2 GHz	34	34	34
	OSL	2 to 10 GHz	44	32	31
	OSL	10 to 20 GHz	40	30	30
	OSL	20 to 35 GHz	41	26	26
	SSS	35 to 50 GHz	42	41	36
	SSS	50 to 67 GHz	40	39	33
Reflection Tracking	OSL	DC to 2 GHz	0.019	0.019	0.020

General Information
Calibration Residual Error Specifications

Table 1-7 (Continued) 85058B (Standard) Residual System Calibration Error

Parameter	Cal Method ^a	Frequency Range	Residuals		
			PNA ^b		PNA ^c
			Data-Based Model ^d Expanded Math Selected	Data-Based Model ^d Expanded Math Unselected	Polynomial Model ^d Expanded Math Unselected
	OSL	2 to 10 GHz	0.010	0.012	0.017
	OSL	10 to 20 GHz	0.033	0.033	0.033
	OSL	20 to 35 GHz	0.033	0.033	0.035
	SSS	35 to 50 GHz	0.027	0.028	0.035
	SSS	50 to 60 GHz	0.030	0.038	0.040
	SSS	60 to 67 GHz	0.030	0.038	0.045

- a. For Expanded Math, all mateable standards in class are measured for the calibration. For example, using the OSL cal method with expanded math measures OSSSSL.
- b. Using the *85058B Data-Based.ckt* (PNA) calibration definitions file.
- c. Using calibration definitions file *85058BP Polynomial.ckt*.
- d. Refer to [“Two Models for Defining Calibration Standards” on page 1-2.](#)

Table 1-8 85058E (Economy) Residual System Calibration Error Specifications

Parameter	Cal Method ^a	Frequency Range	Residuals	
			PNA Data-Based Model ^{b,c}	PNA Polynomial Model ^{b,d}
Directivity	OSL	DC to 2 GHz	30	30
	OSL	2 to 10 GHz	30	30
	OSL	10 to 20 GHz	30	30
	OSL	20 to 35 GHz	30	30
	OSL	35 to 50 GHz	28	28
	OSL	50 to 67 GHz	28	28
Source Match	OSL	DC to 2 GHz	28	28
	OSL	2 to 10 GHz	28	28
	OSL	10 to 20 GHz	27	27
	OSL	20 to 35 GHz	26	23
	OSL	35 to 60 GHz	24	22
	OSL	60 to 67 GHz	24	23
Reflection Tracking	OSL	DC to 2 GHz	0.023	0.025
	OSL	2 to 10 GHz	0.021	0.027
	OSL	10 to 20 GHz	0.029	0.035
	OSL	20 to 35 GHz	0.028	0.035

Table 1-8 (Continued) 85058E (Economy) Residual System Calibration Error Specifications

Parameter	Cal Method ^a	Frequency Range	Residuals	
			PNA Data-Based Model ^{b,c}	PNA Polynomial Model ^{b,d}
	OSL	35 to 60 GHz	0.052	0.062
	OSL	60 to 67 GHz	0.055	0.055

- a. Expanded Math has no effect with the 85058E data-based model or the 85058EP polynomial model.
- b. Refer to [“Two Models for Defining Calibration Standards” on page 1-2](#).
- c. Using the *85058E Data-Based.ckt* (PNA) calibration definitions file.
- d. Using calibration definitions file *85058EP Polynomial.ckt*.

Incoming Inspection

Verify that the shipment is complete by referring to [Figure 6-1 on page 6-5](#) or [Figure 6-2 on page 6-7](#).

Check for damage. The foam-lined storage case provides protection during shipping.

If the case or any device appears damaged, or if the shipment is incomplete, contact Keysight. See [“Contacting Keysight” on page 5-5](#). Keysight will arrange for repair or replacement of incomplete or damaged shipments without waiting for a settlement from the transportation company.

When you send the kit or device to Keysight, include a service tag (found near the end of this manual) with the following information:

- your company name and address
- the name of a technical contact person within your company, and the person's complete phone number
- the model number and serial number of the kit
- the part number and serial number of the device
- the type of service required
- a *detailed* description of the problem

Recording the Device Serial Numbers

In addition to the kit serial number, the devices in this kit are individually serialized (serial numbers are labeled onto the body of each device). Record these serial numbers in [Table 1-9](#) for the 85058B (Standard) and [Table 1-9](#) for the 85058E (Economy). Recording the serial numbers will prevent confusing the devices in this kit with similar devices in other kits.

Table 1-9 Serial Number Record for 85058B (Standard)

Device	Serial Number
Calibration kit	_____
Lowband load –m–	_____
Lowband load –f–	_____
Offset open –m–	_____
Offset open –f–	_____
5.4 mm offset short 1 –m–	_____
5.4 mm offset short 1 –f–	_____
6.3 mm offset short 2 –m–	_____
6.3 mm offset short 2 –f–	_____
7.12 mm offset short 3 –m–	_____
7.12 mm offset short 3 –f–	_____
7.6 mm offset short 4 –m–	_____
7.6 mm offset short 4 –f–	_____
Adapter m–f	_____
Adapter m–m	_____
Adapter f–f	_____

Recording the Device Serial Numbers

Table 1-10 Serial Number Record for 85058E (Economy)

Device	Serial Number
Calibration kit	_____
Broadband termination –m–	_____
Broadband termination –f–	_____
Open –m–	_____
Open –f–	_____
5.4 mm offset short –m–	_____
5.4 mm offset short –f–	_____
Adapter m–f	_____
Adapter m–m	_____
Adapter f–f	_____

Slotted Connectors

The female connectors in this kit have slotted contacts. Therefore, the female devices are instrument grade. Unlike precision slotless connectors, the slotted contacts prevent the devices from being classified as metrology grade.

With slotted connectors, the connected male device partially determines the connector impedance of the female device by flaring the contact fingers and consequently varying the diameter of the female center conductor. Precision slotless connectors prevent diameter variations in the female center conductor, therefore allowing greater control over connector impedance.

Clarifying the Terminology of a Connector Interface

In this document and in the prompts of the PNA calibration wizard, the sex of cable connectors and adapters is referred to in terms of the center conductor. For example, a connector or device designated as 1.85 mm –f– has a 1.85 mm female center conductor.

A connector gage is referred to in terms of the connector that it measures. For instance, a male connector gage has a female connector on the gage so that it can measure male devices.

Preventive Maintenance

The best techniques for maintaining the integrity of the devices in this kit include:

- routine visual inspection
- cleaning
- proper gaging
- proper connection techniques

All of the above are described in [Chapter 3](#). Failure to detect and remove dirt or metallic particles on a mating plane surface can degrade repeatability and accuracy and can damage any connector mated to it. Improper connections, resulting from pin depth values being out of the *observed* limits (see [Table 2-2 on page 2-4](#)), or from bad connections, can also damage these devices.

When to Calibrate

A network analyzer calibration remains valid as long as the changes in the systematic error are insignificant. This means that changes to the uncorrected leakages (directivity and isolation), mismatches (source match and load match), and frequency response of the system are small (<10%) relative to accuracy specifications.

Change in the environment (especially temperature) between calibration and measurement is the major cause in calibration accuracy degradation. The major effect is a change in the physical length of external and internal cables. Other important causes are dirty and damaged test port connectors and calibration standards. If the connectors become dirty or damaged, measurement repeatability and accuracy is affected. Fortunately, it is relatively easy to evaluate the general validity of the calibration. To test repeatability, remeasure one of the calibration standards. If you can not obtain repeatable measurements from your calibration standards, maintenance needs to be performed on the test port connectors, cables and calibration standards. Also, maintain at least one sample of the device under test or some known device as your reference device. A verification kit may be used for this purpose. After calibration, measure the reference device and note its responses. Periodically remeasure the device and note any changes in its corrected response which can be attributed to the test system. With experience you will be able to see changes in the reference responses that indicate a need to perform the measurement calibration again.

General Information
When to Calibrate

2 Specifications

Environmental Requirements

Table 2-1 Environmental Requirements

Parameter	Limits
Operating temperature ^a	+20 °C to +26 °C (+68 °F to +79 °F)
Error-corrected temperature range ^b	±1 °C of measurement calibration temperature
Storage temperature	–40 °C to +75 °C (–40 °F to +167 °F)
Relative humidity	Type tested, 0% to 95% at 40°C, non-condensing

- a. The temperature range over which the calibration standards maintain conformance to their specifications.
- b. The allowable network analyzer ambient temperature drift during measurement calibration and during measurements when the network analyzer error correction is turned on. Also, the range over which the network analyzer maintains its specified performance while correction is turned on.

Temperature—What to Watch Out For

Changes in temperature can affect electrical characteristics. Therefore, the operating temperature is a critical factor in performance. During a measurement calibration, the temperature of the calibration devices must be stable and within the range specified in [Table 2-1](#).

IMPORTANT Avoid unnecessary handling of the devices during calibration because your fingers are a heat source.

Performance verification and measurements of devices under test need not be performed within the operating temperature range of the calibration devices, but they must be within the error-corrected temperature of the network analyzer (± 1 °C of the measurement calibration temperature). For example, if the calibration is performed at +20 °C, the error-corrected temperature range is +19 °C to +21 °C. It is then appropriate to perform measurements and performance verifications at +19 °C, which is outside the operating temperature range of the calibration devices, since only the actual calibration must be performed within the operating temperature range.

Mechanical Characteristics

Mechanical characteristics such as center conductor protrusion and pin depth are *not* performance specifications. They are, however, important supplemental characteristics related to electrical performance. Keysight Technologies verifies the mechanical characteristics of the devices in this kit with special gaging processes and electrical testing. This ensures that the device connectors do not exhibit any improper pin depth when the kit leaves the factory.

“Gaging Procedures” on page 3-10 explains how to use gages to determine if the kit devices have maintained their mechanical integrity. (Refer to Table 2-2 on page 2-4 for typical and observed pin depth limits.)

Pin Depth

Pin depth is the distance the center conductor mating plane differs from being flush with the outer conductor mating plane. See Figure 2-1 The pin depth of a connector can be in one of two states: either protruding or recessed.

Protrusion is the condition in which the center conductor extends beyond the outer conductor mating plane. This condition will indicate a positive value on the connector gage.

Recession is the condition in which the center conductor is set back from the outer conductor mating plane. This condition will indicate a negative value on the connector gage.

Figure 2-1 Connector Pin Depth

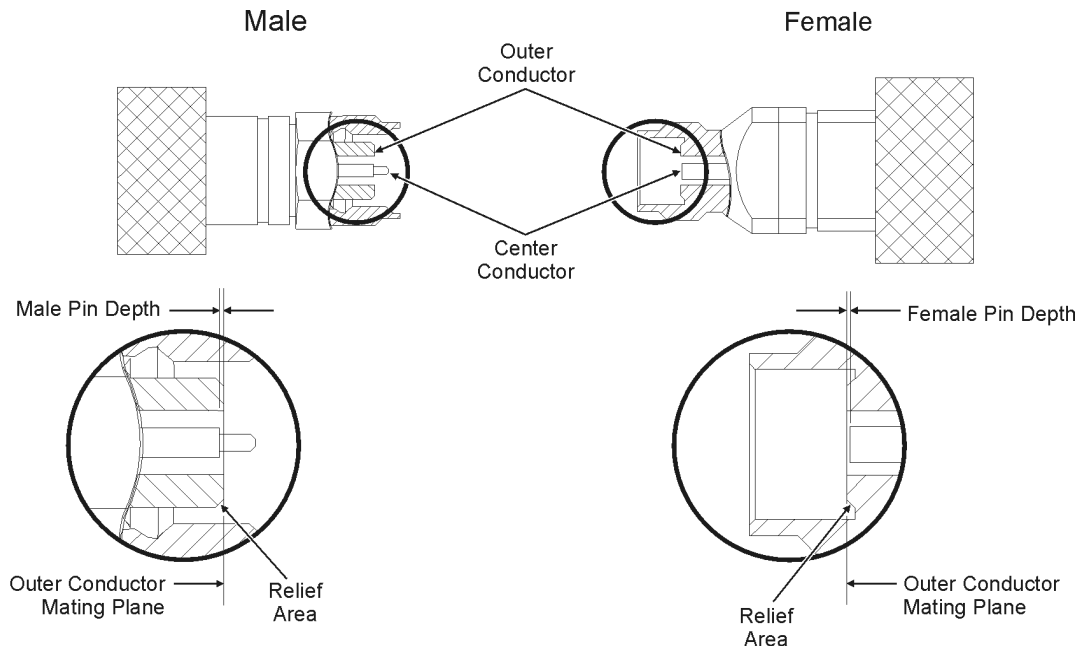

conn185_new

The pin depth value of each calibration device in the kit is not specified, but is an important mechanical parameter. The electrical performance of the device depends, to some extent, on

Electrical Specifications

its pin depth. The electrical specifications for each device in the kit take into account the effect of pin depth on the device's performance. [Table 2-2 on page 2-4](#) lists the typical pin depths and measurement uncertainties, and provides observed pin depth limits for the devices in the kit. If the pin depth of a device does not measure within the *observed* pin depth limits, it may be an indication that the device fails to meet electrical specifications. Refer to [Figure 2-1](#) for a visual representation of proper pin depth (slightly recessed).

Table 2-2 Pin Depth Limit

Device	Typical Pin Depth	Measurement Uncertainty ^a	Observed Pin Depth Limits ^b
Opens	-0.005 to -0.015 mm -0.0002 to -0.00059 in	+0.0030 to -0.0030 mm +0.00012 to -0.00012 in	-0.0020 to -0.0180 mm -0.00008 to -0.00071 in
Shorts	0 to -0.0127 mm 0 to -0.0005 in	+0.0015 to -0.0015 mm +0.00006 to -0.00006 in	+0.0015 to -0.0142 mm +0.00006 to -0.00056 in
Fixed Loads and Terminations	-0.0025 to -0.0203 mm -0.0001 to -0.0008 in	+0.0030 to -0.0030 mm +0.00012 to -0.00012 in	+0.0005 to -0.0233 mm +0.00002 to -0.00092 in
Adapters	0 to -0.0381 mm 0 to -0.0015 in	+0.0030 to -0.0030 mm +0.00012 to -0.00012 in	+0.0030 to -0.0411 mm +0.00012 to -0.00162 in

- a. Approximately +2 sigma to -2 sigma of gage uncertainty based on studies done at the factory according to recommended procedures.
- b. Observed pin depth limits are the range of observation limits seen on the gage reading due to measurement uncertainty. The depth could still be within specifications.

Electrical Specifications

The electrical specifications in [Table 2-3](#) through [Table 2-4](#) apply to the devices in your calibration kit when connected with a Keysight precision interface.

Table 2-3 85058B (Standard) Electrical Specifications for 1.85 mm Devices

Device	Frequency	Parameter	Specifications			
			Male		Female	
			Polynomial Model	Data-Based Model	Polynomial Model	Data-Based Model
Lowband load	DC to 10 GHz	Return Loss (dB)	36	36	35	35
	10 to 20 GHz		34	34	34	34
	20 to 35 GHz		31	31	29	29
	35 to 60 GHz ^a		22	22	12	12
	60 to 67 GHz ^a		19	19	10	10
Open	DC to 10 GHz	Deviation from Nominal Phase (degrees)	2.2	2.0	2.7	2.5
	10 to 35 GHz		3.2	3.0	3.7	3.5
	35 to 50 GHz		NA ^b	3.0	NA ^b	3.5
	50 to 67 GHz		NA ^b	4.5	NA ^b	5.0
Short 1	DC to 20 GHz	Deviation from Nominal Phase (degrees)	1.7	1.5	1.7	1.5
	20 to 30 GHz		2.2	2.0	2.2	2.0
	30 to 35 GHz		2.2	2.0	2.7	2.5
	35 to 40 GHz		NA ^b	2.0	NA ^b	2.5
	40 to 50 GHz		NA ^b	2.0	NA ^b	3.5

Electrical Specifications

Table 2-3 (Continued) 85058B (Standard) Electrical Specifications for 1.85 mm Devices

Device	Frequency	Parameter	Specifications			
			Male		Female	
			Polynomial Model	Data-Based Model	Polynomial Model	Data-Based Model
	50 to 67 GHz		NA ^b	3.0	NA ^b	4.0
Short 2	DC to 20 GHz	Deviation from Nominal Phase (degrees)	NA ^b	1.5	NA ^b	1.5
	20 to 30 GHz		NA ^b	2.0	NA ^b	2.0
	30 to 35 GHz		NA ^b	2.0	NA ^b	2.5
	35 to 40 GHz		2.4	2.0	2.9	2.5
	40 to 50 GHz		2.6	2.0	4.1	3.5
	50 to 67 GHz		3.6	3.0	4.6	4.0
Short 3	DC to 20 GHz	Deviation from Nominal Phase (degrees)	NA ^b	1.5	NA ^b	1.5
	20 to 30 GHz		NA ^b	2.0	NA ^b	2.0
	30 to 35 GHz		NA ^b	2.0	NA ^b	2.5
	35 to 40 GHz		2.4	2.0	2.9	2.5
	40 to 50 GHz		2.6	2.0	4.1	3.5
	50 to 67 GHz		4.4	3.0	5.4	4.0
Short 4	DC to 20 GHz	Deviation from Nominal Phase (degrees)	NA ^b	1.5	NA ^b	1.5

Table 2-3 (Continued) 85058B (Standard) Electrical Specifications for 1.85 mm Devices

Device	Frequency	Parameter	Specifications			
			Male		Female	
			Polynomial Model	Data-Based Model	Polynomial Model	Data-Based Model
	20 to 30 GHz		NA ^b	2.0	NA ^b	2.0
	30 to 35 GHz		NA ^b	2.0	NA ^b	2.5
	35 to 40 GHz		2.7	2.0	2.9	2.5
	40 to 50 GHz		3.1	2.0	4.6	3.5
	50 to 67 GHz		4.2	3.0	5.2	4.0

Device	Frequency	Parameter	Specifications	
			Return Loss (dB)	Insertion Loss (dB)
Adapters	DC to 4 GHz		33	0.3
	4 to 26.5 GHz		24	0.5
	26.5 to 50 GHz		22	0.7
	50 to 67 GHz		20	0.9

- a. Typical performance.
- b. This cal device is not used in this frequency range when your calibration is using a polynomial model with Expanded Math unselected. Refer to [“Two Models for Defining Calibration Standards” on page 1-2.](#)

Electrical Specifications

Table 2-4 85058E (Economy) Electrical Specifications for 1.85 mm Devices

Device	Frequency	Parameter	Specifications			
			Male		Female	
			Polynomial Model	Data-Based Model	Polynomial Model	Data-Based Model
Broadband Termination	DC to 35 GHz	Return Loss (dB)	30	30	30	30
	35 to 67 GHz		28	28	28	28
Open	DC to 10 GHz	Deviation from Nominal Phase (degrees)	2.5	2.0	3.0	2.5
	10 to 50 GHz		4.0	3.0	4.5	3.5
	50 to 67 GHz		5.5	4.5	6.0	5.0
Short 1	DC to 20 GHz	Deviation from Nominal Phase (degrees)	2.0	1.5	2.0	1.5
	20 to 30 GHz		3.0	2.0	3.0	2.0
	30 to 40 GHz		3.0	2.0	3.5	2.5
	40 to 50 GHz		3.0	2.0	4.5	3.5
	50 to 67 GHz		4.0	3.0	5.0	4.0

Table 2-4 (Continued) 85058E (Economy) Electrical Specifications for 1.85 mm Devices

Device	Frequency	Parameter	Specifications	
			Return Loss (dB)	Insertion Loss (dB)
Adapters	DC to 4 GHz		33	0.3
	4 to 26.5 GHz		24	0.5
	26.5 to 50 GHz		22	0.7
	50 to 67 GHz		20	0.9

Certification

Keysight Technologies certifies that this product met its published specifications at the time of shipment from the factory. Keysight further certifies that its calibration measurements are traceable to the United States National Institute of Standards and Technology (NIST) to the extent allowed by the institute’s calibration facility, and to the calibration facilities of other International Standards Organization members. See [“How Keysight Verifies the Devices in This Kit” on page 4-2](#) for more information.

Specifications
Electrical Specifications

3 Use, Maintenance, and Care of the Devices

Electrostatic Discharge

Protection against ESD (electrostatic discharge) is essential while connecting, inspecting, or cleaning connectors attached to a static-sensitive circuit (such as those found in test sets).

Static electricity can build up on your body and can easily damage sensitive internal circuit elements when discharged. Static discharges too small to be felt can cause permanent damage. Devices such as calibration components and devices under test (DUTs), can also carry an electrostatic charge. To prevent damage to the test set, components, and devices:

- *always* wear a grounded wrist strap having a 1 M Ω resistor in series with it when handling components and devices or when making connections to the test set.
- *always* use a grounded, conductive table mat while making connections.
- *always* wear a heel strap when working in an area with a conductive floor. If you are uncertain about the conductivity of your floor, wear a heel strap.
- *always* ground yourself before you clean, inspect, or make a connection to a static-sensitive device or test port. You can, for example, grasp the grounded outer shell of the test port or cable connector briefly.
- *always* ground the center conductor of a test cable before making a connection to the analyzer test port or other static-sensitive device. This can be done as follows:
 1. Connect a short (from your calibration kit) to one end of the cable to short the center conductor to the outer conductor.
 2. While wearing a grounded wrist strap, grasp the outer shell of the cable connector.
 3. Connect the other end of the cable to the test port.
 4. Remove the short from the cable.

Refer to [Chapter 6](#) for part numbers and instructions for ordering ESD protection devices.

Figure 3-1 ESD Protection Setup

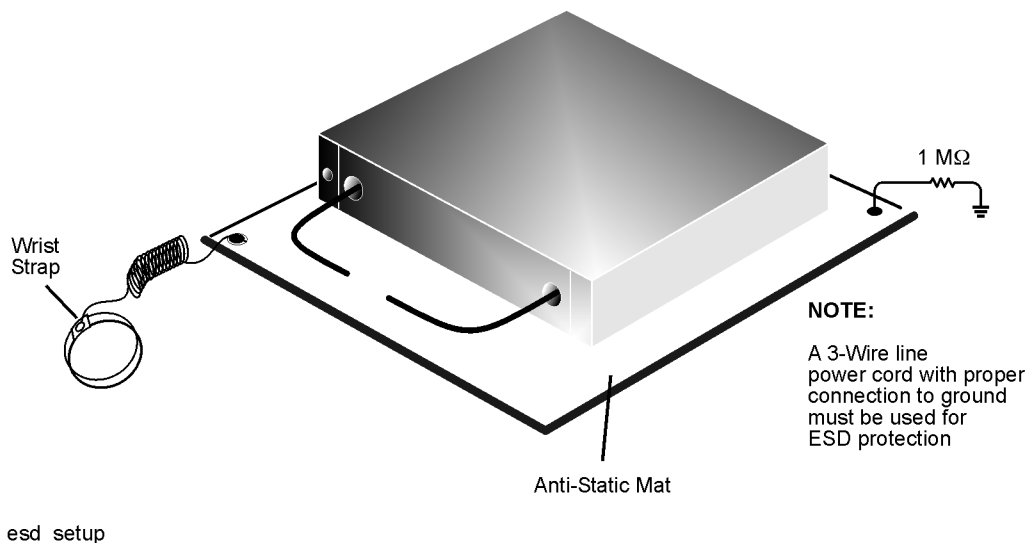

Visual Inspection

Visual inspection and, if necessary, cleaning should be done every time a connection is made. Metal particles from the connector threads may fall into the connector when it is disconnected. One connection made with a dirty or damaged connector can damage both connectors beyond repair.

Magnification is helpful when inspecting connectors, but it is not required and may actually be misleading. Defects and damage that cannot be seen without magnification generally have no effect on electrical or mechanical performance. Magnification is of great use in analyzing the nature and cause of damage and in cleaning connectors, but it is not required for inspection.

Look for Obvious Defects and Damage First

Examine the connectors first for obvious defects and damage: badly worn plating on the connector interface, deformed threads, or bent, broken, or misaligned center conductors. Connector nuts should move smoothly and be free of burrs, loose metal particles, and rough spots.

What Causes Connector Wear?

Connector wear is caused by connecting and disconnecting the devices. The more use a connector gets, the faster it wears and degrades. The wear is greatly accelerated when connectors are not kept clean, or are connected incorrectly.

Connector wear eventually degrades performance of the device. Calibration devices should have a long life if their use is on the order of a few times per week. Replace devices with worn connectors.

The test port connectors on the network analyzer test set may have many connections each day, and are therefore more subject to wear. It is recommended that an adapter be used as a test port saver to minimize the wear on the test set's test port connectors.

Connector Contacts

See [Figure 3-2 on page 3-4](#) for visual guidelines when evaluating the contact integrity of a connector.

NOTE Notice the location of the cross hairs in relationship to the center of the figures.

Visual Inspection

Figure 3-2 Contact Integrity

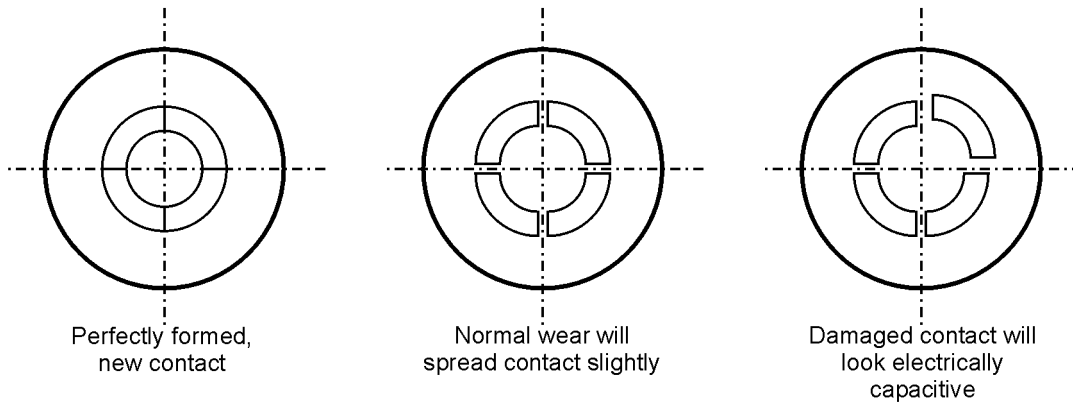

integ

Concentricity

Figure 3-3 and Figure 3-4 show the concentricity of both the male and female 1.85 mm connectors. Inspect the connectors with a minimum magnification of 10X.

Figure 3-3 Concentricity of a Female Connector

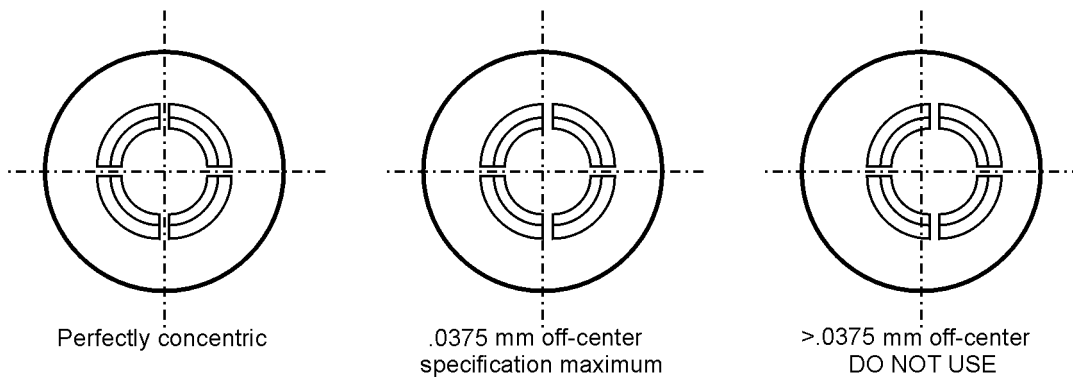

feconnect

Figure 3-4 Concentricity of a Male Connector

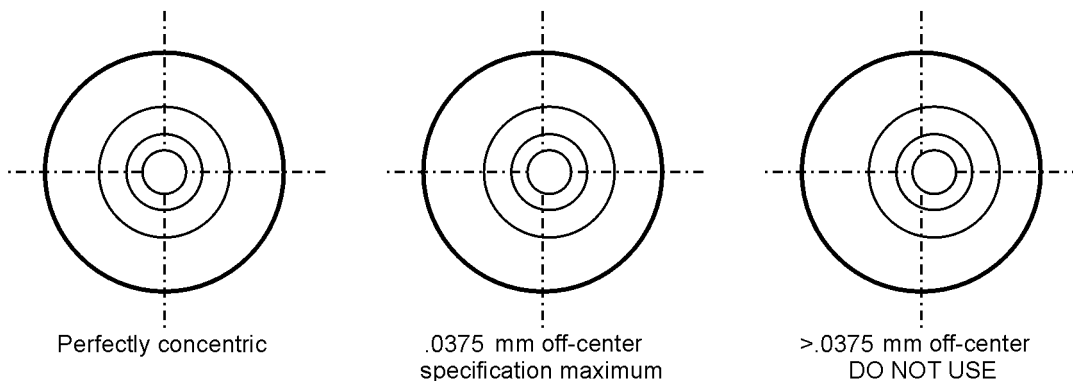

maconnect

Inspect the Mating Plane Surfaces

Flat contact between the connectors at all points on their mating plane surfaces is required for a good connection. See [Figure 2-1 on page 2-3](#). Look especially for deep scratches or dents, and for dirt and metal particles on the connector mating plane surfaces. Also look for signs of damage due to excessive or uneven wear or misalignment.

Light burnishing of the mating plane surfaces is normal, and is evident as light scratches or shallow circular marks distributed more or less uniformly over the mating plane surface. Other small defects and cosmetic imperfections are also normal. None of these affect electrical or mechanical performance.

If a connector shows deep scratches or dents, particles clinging to the mating plane surfaces, or uneven wear, clean and inspect it again. Devices with damaged connectors should be discarded. Determine the cause of damage before connecting a new, undamaged connector in the same configuration.

Inspect Female Connectors

Pay special attention to the contact fingers in the female center conductor. These can be bent or broken, and damage to them is not always easy to see. A connector with damaged contact fingers will negatively affect electrical performance and must be replaced.

NOTE Inspection is particularly important when mating nonprecision to precision devices.

Cleaning Connectors

Clean connectors are essential for ensuring the integrity of RF and microwave coaxial connections.

1. Use Compressed Air or Nitrogen

WARNING Always use protective eyewear when using compressed air or nitrogen.

Use compressed air (or nitrogen) to loosen particles on the connector mating plane surfaces.

You can use any source of clean, dry, low-pressure compressed air or nitrogen that has an effective oil-vapor filter and liquid condensation trap placed just before the outlet hose.

Ground the hose nozzle to prevent electrostatic discharge, and set the air pressure to less than 414 kPa (60 psi) to control the velocity of the air stream. High-velocity streams of compressed air can cause electrostatic effects when directed into a connector. These electrostatic effects can damage the device. Refer to “[Electrostatic Discharge](#)” earlier in this chapter for additional information.

2. Clean the Connector Threads

WARNING Keep isopropyl alcohol away from heat, sparks, and flame. Store in a tightly closed container. It is extremely flammable. In case of fire, use alcohol foam, dry chemical, or carbon dioxide; water may be ineffective.

Use isopropyl alcohol with adequate ventilation and avoid contact with eyes, skin, and clothing. It causes skin irritation, may cause eye damage, and is harmful if swallowed or inhaled. It may be harmful if absorbed through the skin. Wash thoroughly after handling.

In case of spill, soak up with sand or earth. Flush spill area with water.

Dispose of isopropyl alcohol in accordance with all applicable federal, state, and local environmental regulations.

Use a lint-free swab or cleaning cloth moistened with isopropyl alcohol to remove any dirt or stubborn contaminants on a connector that cannot be removed with compressed air or nitrogen. Refer to [Table 6-3 on page 6-8](#) for a part numbers for cleaning swabs.

- a. Apply a small amount of isopropyl alcohol to a lint-free cleaning swab.
- b. Clean the connector threads.
- c. Let the alcohol evaporate, then blow the threads dry with a gentle stream of clean, low-pressure compressed air or nitrogen. Always completely dry a connector before you reassemble or use it.

3. Clean the Mating Plane Surfaces

- a. Apply a small amount of isopropyl alcohol to a lint-free cleaning swab.
- b. Clean the center and outer conductor mating plane surfaces. Refer to [Figure 2-1 on](#)

page 2-3. When cleaning a female connector, avoid snagging the swab on the center conductor contact fingers by using short strokes.

- c. Let the alcohol evaporate, then blow the connector dry with a gentle stream of clean, low-pressure compressed air or nitrogen. Always completely dry a connector before you reassemble or use it.

4. Reinspect

Inspect the connector again to make sure that no particles or residue are present.

Gaging Connectors

The gages available from Keysight Technologies are intended for preventive maintenance and troubleshooting purposes only. (See [Table 6-3 on page 6-8](#) for part number information.) They are effective in detecting excessive center conductor protrusion or recession, and conductor damage on DUTs, test accessories, and the calibration kit devices. *Do not use the gages for precise pin depth measurements.*

Connector Gage Accuracy

The connector gages are only capable of performing coarse measurements. They do not provide the degree of accuracy necessary to precisely measure the pin depth of the kit devices. This is partially due to the repeatability uncertainties that are associated with the measurement. Only the factory—through special gaging processes and electrical testing— can accurately verify the mechanical characteristics of the devices.

With proper technique, however, the gages are useful in detecting gross pin depth errors on device connectors. To achieve maximum accuracy, random errors must be reduced by taking the average of at least three measurements having different gage orientations on the connector. Even the resultant average can be in error by as much as ± 0.0001 inch due to systematic (biasing) errors usually resulting from worn gages and gage masters. The information in [Table 2-2 on page 2-4](#) assumes new gages and gage masters. Therefore, these systematic errors were not included in the uncertainty analysis. As the gages undergo more use, the systematic errors can become more significant in the accuracy of the measurement.

The measurement uncertainties (see [Table 2-2 on page 2-4](#)) are primarily a function of the assembly materials and design, and the unique interaction each device type has with the gage. Therefore, these uncertainties can vary among the different devices. For example, note the difference between the uncertainties of the opens and shorts in [Table 2-2](#).

The observed pin depth limits in [Table 2-2](#) add these uncertainties to the typical factory pin depth values to provide practical limits that can be referenced when using the gages. See “[Pin Depth](#)” on [page 2-3](#). Refer to “[85058B \(Standard\) Kit Contents](#)” on [page 1-4](#) and “[85058E \(Economy\) Kit Contents](#)” on [page 1-5](#) for more information on the design of the calibration devices in this kit.

NOTE When measuring pin depth, the measured value (resultant average of three or more measurements) contains measurement uncertainty and is not necessarily the true value. Always compare the measured value with the *observed* pin depth limits (which account for measurement uncertainties) in [Table 2-2 on page 2-4](#) to evaluate the condition of device connectors.

When to Gage Connectors

Gage a connector at the following times:

- Prior to using a device for the first time: record the pin depth measurement so that it can be compared with future readings. (It will serve as a good troubleshooting tool when you suspect damage may have occurred to the device.)
- If either visual inspection or electrical performance suggests that the connector interface may be out of typical range (due to wear or damage, for example).
- If a calibration device is used by someone else or on another system or piece of equipment.
- Initially after every 100 connections, and after that as often as experience indicates.

Gaging Procedures

Gaging Male 1.85 mm Connectors

NOTE Always hold a connector gage by the gage barrel, below the dial indicator. This gives the best stability, and improves measurement accuracy. (Cradling the gage in your hand or holding it by the dial applies stress to the gage plunger mechanism through the dial indicator housing.)

1. Select the proper gage for your connector. The 1.85 mm connectors are gaged with the same gages and in the same way as precision 2.4 mm connectors. Refer to [Table 6-3 on page 6-8](#) for gage part numbers.
2. Inspect and clean the gage, gage master, and device to be gaged. Refer to [“Visual Inspection”](#) and [“Cleaning Connectors”](#) earlier in this chapter.
3. Zero the connector gage (refer to [Figure 3-5](#)):
 - a. While holding the gage by the barrel, and without turning the gage or the device, screw the male gage master connecting nut onto the male gage, just until you meet resistance. Connect the nut finger tight. Do not overtighten.
 - b. Use the torque wrench recommended for use with the kit to tighten the connecting nut to 90 N-cm (8 in-lb). Refer to [“Connections” on page 3-14](#) for more information.
 - c. As you watch the gage pointer, gently tap the barrel of the gage to settle the reading.
The gage pointer should line up exactly with the zero mark on the gage. If not, adjust the zero set knob until the gage pointer lines up exactly with zero.
 - d. Remove the gage master.
4. Gage the device connector (refer to [Figure 3-5](#)):
 - a. While holding the gage by the barrel, and without turning the gage or the device, screw the connecting nut of the male device being measured onto the male gage, just until you meet resistance. Connect the nut finger-tight. Do not overtighten.
 - b. Use the torque wrench recommended for use with the kit to tighten the connecting nut to 90 N-cm (8 in-lb). Refer to [“Connections” on page 3-14](#) for more information.
 - c. Gently tap the barrel of the gage with your finger to settle the gage reading.
 - d. Read the gage indicator dial. Read *only* the black \pm signs; *not* the red \pm signs.
For maximum accuracy, measure the connector a minimum of three times and take an average of the readings. After each measurement, rotate the gage a quarter-turn to reduce measurement variations that result from the gage or the connector face not being exactly perpendicular to the center axis.
 - e. Compare the average reading with the observed pin depth limits in [Table 2-2 on page 2-4](#).

Figure 3-5 Gaging Male 1.85 mm Connectors

Zero the Connector Gage

- Screw the male gage master connecting nut onto the male gage.
- Torque the connecting nut.
- Gently tap the gage barrel to settle the reading.
- Using the zero set knob, adjust the gage pointer to line up exactly with the zero mark.
- Remove the gage master.

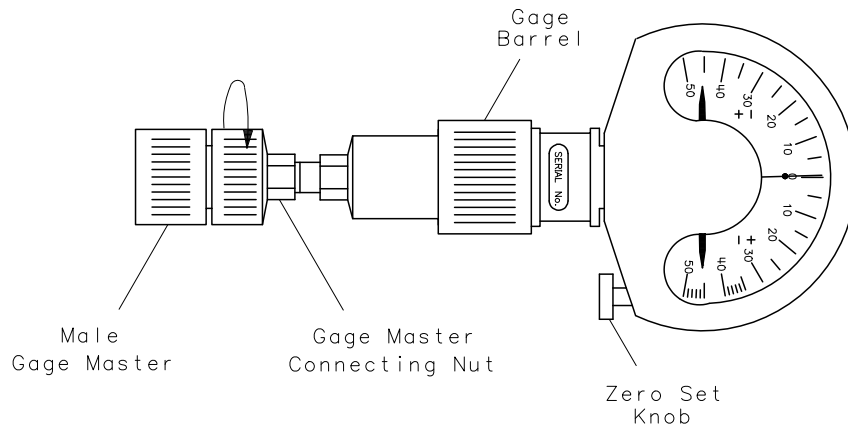

Gage the Device Connector

- Screw the male device connecting nut onto the male gage.
- Torque the connecting nut.
- Gently tap the gage barrel to settle the reading.
- Read recession or protrusion from the gage.
- Remove the device.

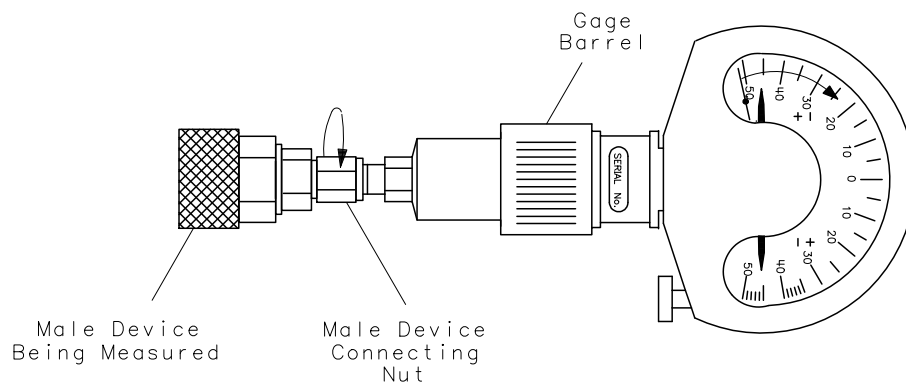

wj615d

Gaging Female 1.85 mm Connectors

NOTE Always hold a connector gage by the gage barrel, below the dial indicator. This gives the best stability, and improves measurement accuracy. (Cradling the gage in your hand or holding it by the dial applies stress to the gage plunger mechanism through the dial indicator housing.)

1. Select the proper gage for your connector. The 1.85 mm connectors are gaged with the same gages and in the same way as precision 2.4 mm connectors. Refer to [Table 6-3 on page 6-8](#) for gage part numbers.
2. Inspect and clean the gage, gage master, and device to be gaged. Refer to [“Visual Inspection”](#) and [“Cleaning Connectors”](#) earlier in this chapter.
3. Zero the connector gage (refer to [Figure 3-6](#)):
 - a. While holding the gage by the barrel, and without turning the gage or the device, screw the female gage connecting nut onto the female gage master, just until you meet resistance. Connect the nut finger-tight. Do not overtighten.
 - b. Use the torque wrench recommended for use with the kit to tighten the connecting nut to 90 N-cm (8 in-lb). Refer to [“Connections” on page 3-14](#) for more information.
 - c. As you watch the gage pointer, gently tap the barrel of the gage to settle the reading.
The gage pointer should line up exactly with the zero mark on the gage. If not, adjust the zero set knob until the gage pointer lines up exactly with zero.
 - d. Remove the gage master.
4. Gage the device connector (refer to [Figure 3-6](#)):
 - a. While holding the gage by the barrel, and without turning the gage or the device, screw the female gage connecting nut onto the female device being measured, just until you meet resistance. Connect the nut finger-tight. Do not overtighten.
 - b. Use the torque wrench recommended for use with the kit to tighten the connecting nut to 90 N-cm (8 in-lb). Refer to [“Connections” on page 3-14](#) for more information.
 - c. Gently tap the barrel of the gage with your finger to settle the gage reading.
 - d. Read the gage indicator dial. Read *only* the black \pm signs; *not* the red \pm signs.
For maximum accuracy, measure the connector a minimum of three times and take an average of the readings. Use different orientations of the gage within the connector. After each measurement, rotate the gage a quarter-turn to reduce measurement variations that result from the gage or the connector face not being exactly perpendicular to the center axis.
 - e. Compare the average reading with the observed pin depth limits in [“Pin Depth Limit” on page 2-4](#).

Figure 3-6 Gaging Female 1.85 mm Connectors

Zero the Connector Gage

- Screw the female gage connecting nut onto the female gage master.
- Torque the connecting nut.
- Gently tap the gage barrel to settle the reading.
- Using the zero set knob, adjust the gage pointer to line up exactly with the zero mark.
- Remove the gage master.

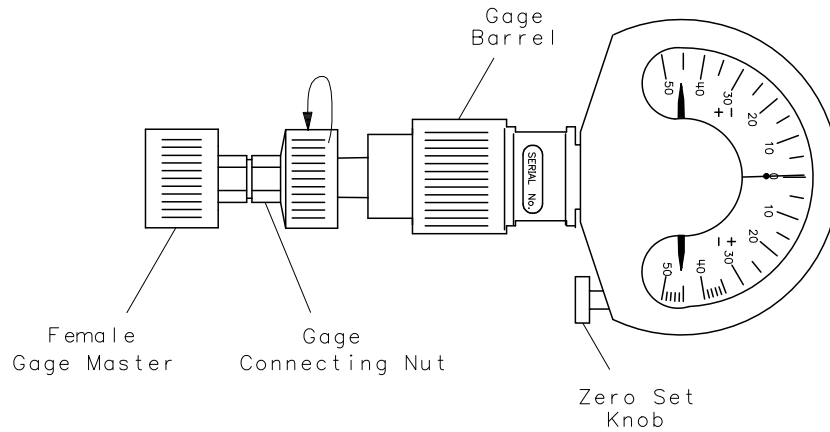

Gage the Device Connector

- Screw the female gage connecting nut onto the female device.
- Torque the connecting nut.
- Gently tap the gage barrel to settle the reading.
- Read recession or protrusion from the gage.
- Remove the device.

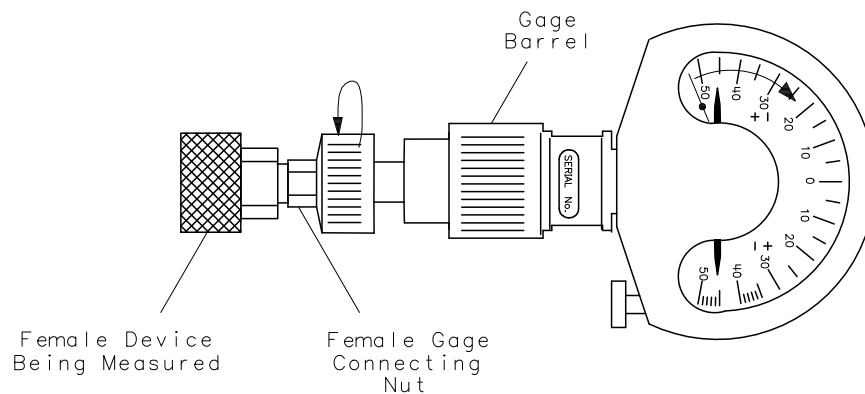

wj616d

Connections

Good connections require a skilled operator. *The most common cause of measurement error is bad connections.* The following procedures illustrate how to make good connections.

How to Make a Connection

Preliminary Connection

1. Ground yourself and all devices. Wear a grounded wrist strap and work on a grounded, conductive table mat. Refer to “[Electrostatic Discharge](#)” on page 3-2 for ESD precautions.
2. Visually inspect the connectors. Refer to “[Visual Inspection](#)” on page 3-3.
3. If necessary, clean the connectors. Refer to “[Cleaning Connectors](#)” on page 3-6.
4. Use a connector gage to verify that all center conductors are within the observed pin depth values in [Table 2-2 on page 2-4](#). Refer to “[Gaging Connectors](#)” on page 3-8.
5. Carefully align the connectors. The male connector center pin must slip concentrically into the contact finger of the female connector.
6. Push the connectors straight together.

CAUTION Do *not* turn the device body. Only turn the connector nut. Damage to the center conductor and outer conductor can occur if the device body is twisted.

Do *not* twist or screw the connectors together. As the center conductors mate, there is usually a slight resistance.

7. The preliminary connection is tight enough when the mating plane surfaces make uniform, light contact. Do not overtighten this connection.

A connection in which the outer conductors make gentle contact at all points on both mating surfaces is sufficient. Very light finger pressure is enough to accomplish this.

8. Make sure the connectors are properly supported. Relieve any side pressure on the connection from long or heavy devices or cables.

Final Connection Using a Torque Wrench

1. Use a torque wrench to make a final connection. [Table 3-1](#) provides information about the torque wrench recommended for use with this calibration kit. A torque wrench is *not* included in the 85058E (Economy) calibration kit. Refer to [Table 6-3 on page 6-8](#) for part number and ordering information.

Table 3-1 Torque Wrench Information

Connector Type	Torque Setting	Torque Tolerance
1.85 mm	90 N-cm (8 in-lb)	±9 N-cm (±0.8 in-lb)

Using a torque wrench guarantees that the connection is not too tight, preventing possible connector damage. It also guarantees that all connections are equally tight each time.

2. Prevent the rotation of anything other than the connector nut that you are tightening. It may be possible to do this by hand if one of the connectors is fixed (as on a test port). In all situations, however, it is recommended that you use an open-end wrench to keep the body of the device from turning. Refer to **Chapter 6** for part number and ordering information.
3. Position both wrenches within 90 degrees of each other before applying force. See **Figure 3-7**. Wrenches opposing each other (greater than 90 degrees apart) will cause a lifting action which can misalign and stress the connections of the devices involved. This is especially true when several devices are connected together.

Figure 3-7 Wrench Positions

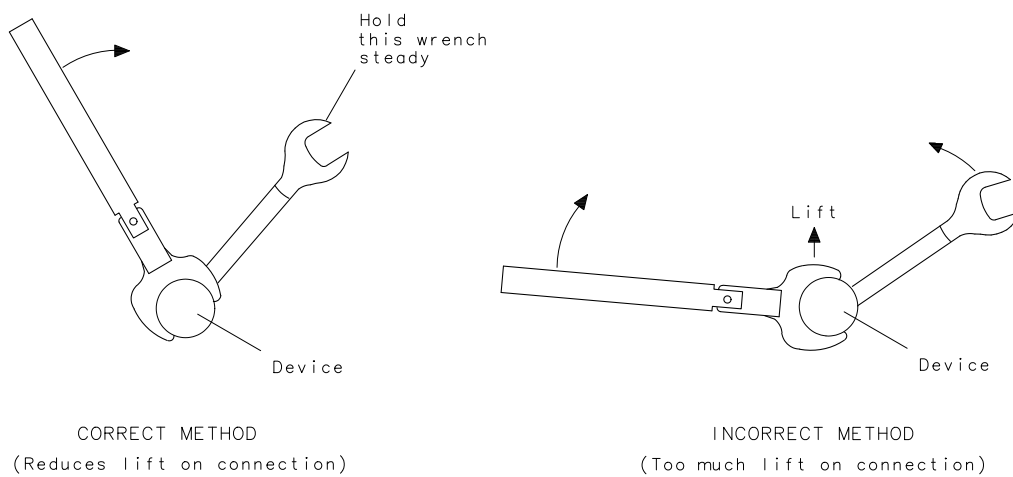

wj56f

4. Hold the torque wrench lightly, at the end of the handle only (beyond the groove). See **Figure 3-8**.

Figure 3-8 Using the Torque Wrench

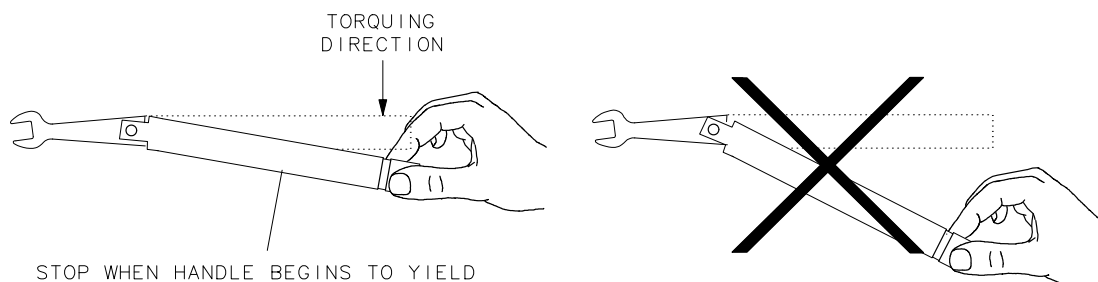

wj68d

5. Apply downward force perpendicular to the wrench handle. See **Figure 3-8**. This applies

Handling and Storage

torque to the connection through the wrench.

Do not hold the wrench so tightly that you push the handle straight down along its length rather than pivoting it, otherwise you apply an unknown amount of torque.

6. Tighten the connection just to the torque wrench break point. The wrench handle gives way at its internal pivot point. See [Figure 3-8](#). Do not tighten the connection further.

CAUTION You don't have to fully break the handle of the torque wrench to reach the specified torque; doing so can cause the handle to kick back and loosen the connection. Any give at all in the handle is sufficient torque.

Do not pivot the wrench handle on your thumb or other fingers, otherwise you apply an unknown amount of torque to the connection when the wrench reaches its break point.

Do not twist the head of the wrench relative to the outer conductor mating plane. If you do, you apply more than the recommended torque.

How to Separate a Connection

To avoid lateral (bending) force on the connector mating plane surfaces, always support the devices and connections.

CAUTION Turn the connector nut, *not* the device body. Major damage to the center conductor can occur if the device body is twisted.

1. Use an open-end wrench to prevent the device body from turning.
2. Use another open-end wrench to loosen the connector nut.
3. Complete the separation by hand, turning only the connector nut.
4. Pull the connectors straight apart without twisting, rocking, or bending either of the connectors.

Handling and Storage

- Install the protective end caps and store the calibration devices in the foam-lined storage case when not in use.
- Never store connectors loose in a box, desk, or bench drawer. This is the most common cause of connector damage during storage.
- Keep connectors clean.
- Do not touch mating plane surfaces. Natural skin oils and microscopic particles of dirt are easily transferred to a connector interface and are very difficult to remove.
- Do not set connectors contact-end down on a hard surface. The plating and the mating plane surfaces can be damaged if the interface comes in contact with any hard surface.

4 Performance Verification

Introduction

The performance of your calibration kit can only be verified by returning the kit to Keysight Technologies for recertification. The equipment required to verify the specifications of the devices in the kit has been specially manufactured and is not commercially available.

How Keysight Verifies the Devices in This Kit

Keysight verifies the specifications of these devices as follows:

1. The residual microwave error terms of the test system are verified with precision airlines and shorts that are directly traced to NIST (National Institute of Standards and Technology). The airline and short characteristics are developed from mechanical measurements. The mechanical measurements and material properties are carefully modeled to give very accurate electrical representation. The mechanical measurements are then traced to NIST through various plug and ring gages and other mechanical measurements.
2. Each calibration device is electrically tested on this system. For the initial (before sale) testing of the calibration devices, Keysight includes the test measurement uncertainty as a guardband to guarantee each device meets the published specification. For recertifications (after sale), no guardband is used and the measured data is compared directly with the specification to determine the pass or fail status. The measurement uncertainty for each device is, however, recorded in the calibration report that accompanies recertified kits.

These two steps establish a traceable link to NIST for Keysight to the extent allowed by the institute's calibration facility. The specifications data provided for the devices in this kit is traceable to NIST through Keysight Technologies.

Recertification

The following will be provided with a recertified kit:

- a new calibration sticker affixed to the case
- a certificate of calibration
- a calibration report for each device in the kit listing measured values, specifications, and uncertainties

NOTE A list of NIST traceable numbers may be purchased upon request to be included in the calibration report.

Keysight Technologies offers a *Standard* calibration for the recertification of this kit. For more information, contact Keysight Technologies - refer to [“Contacting Keysight” on page 5-5](#).

How Often to Recertify

The suggested initial interval for recertification is 12 months or sooner. The actual need for recertification depends on the use of the kit. After reviewing the results of the initial recertification, you may establish a different recertification interval that reflects the usage and wear of the kit.

NOTE The recertification interval should begin on the date the kit is *first used* after the recertification date.

Where to Send a Kit for Recertification

Contact Keysight Technologies for information on where to send your kit for recertification. See [“Contacting Keysight” on page 5-5](#).

When you return the kit, complete and attach a service tag. Refer to [“Returning a Kit or Device to Keysight” on page 5-4](#) for details.

Performance Verification
Recertification

5 Troubleshooting

Troubleshooting Process

If you suspect a bad calibration, or if your network analyzer does not pass performance verification, follow the steps in [Figure 5-1](#).

Figure 5-1 Troubleshooting Flowchart

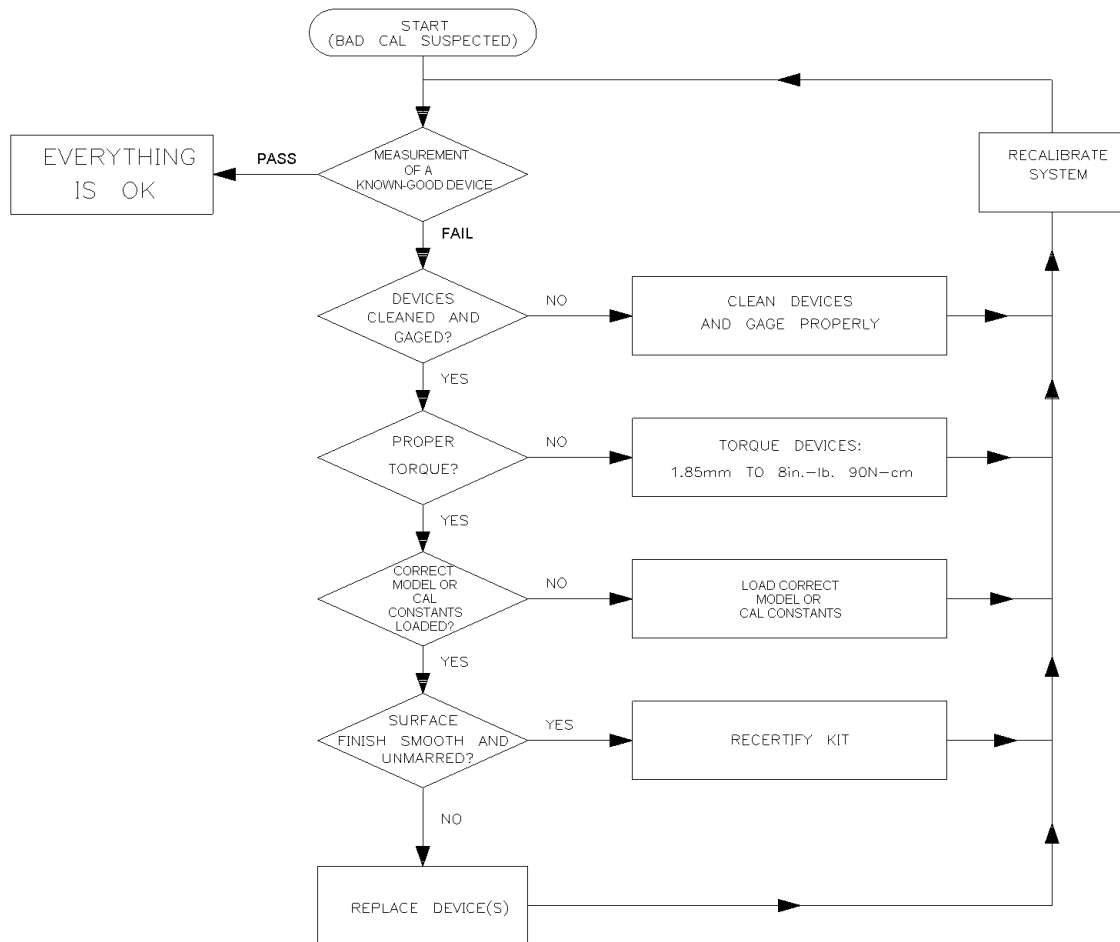

Where to Look for More Information

This manual contains limited information about network analyzer system operation. For detailed information on using an ENA or PNA series network analyzer, refer to the appropriate user guide or Help file.

- To view the ENA or PNA Help, press the Help key on the front panel of the network analyzer.
- To view Help or a user guide online, use the following steps:
 1. Go to www.keysight.com.
 2. Enter your analyzer model number (Ex: N5242A) in the Search box and click **Search**.
 3. Under the heading **Manuals**, click on the title/hyperlink for the document PDF you want to view.

If you need additional information, see “[Contacting Keysight](#)” on page 5-5.

Returning a Kit or Device to Keysight

If your kit or device requires service, contact Keysight Technologies for information on where to send it. See “[Contacting Keysight](#)” on [page 5-5](#) for information. Include a service tag (located near the end of this manual) on which you provide the following information:

- your company name and address
- a technical contact person within your company, and the person's complete phone number
- the model number and serial number of the kit
- the part number and serial number of each device
- the type of service required
- a *detailed* description of the problem and how the device was being used when the problem occurred (such as calibration or measurement)

Contacting Keysight

Assistance with test and measurements needs and information on finding a local Keysight office are available on the Web at:

www.keysight.com/find/assist

If you do not have access to the Internet, please contact your Keysight field engineer.

NOTE In any correspondence or telephone conversation, refer to the Keysight product by its model number and full serial number. With this information, the Keysight representative can determine whether your product is still within its warranty period.

6 Replaceable Parts

Introduction

Table 6-1 lists the replacement part numbers for items included in the 85058B (Standard) calibration kit and **Figure 6-1** illustrates each of these items.

Table 6-2 lists the replacement part numbers for items included in the 85058B (Economy) calibration kit and **Figure 6-2** illustrates each of these items.

Table 6-3 lists the replacement part numbers for items recommended or required for successful operation but not included in the calibration kit.

To order a listed part, note the description, the part number, and the quantity desired. Telephone or send your order to Keysight Technologies. See **“Contacting Keysight” on page 5-5**.

Table 6-1 Replaceable Parts for the 85058B (Standard) Calibration Kit

Description	Qty Per Kit	Keysight Part Number
Calibration Devices (1.85 mm)^{a,b}		
5.4 mm offset short 1 –m–	1	85058-60101
6.3 mm offset short 2 –m–	1	85058-60102
7.12 mm offset short 3 –m–	1	85058-60103
7.6 mm offset short 4 –m–	1	85058-60104
5.4 mm offset short 1 –f–	1	85058-60105
6.3 mm offset short 2 –f–	1	85058-60106
7.12 mm offset short 3 –f–	1	85058-60107
7.6 mm offset short 4 –f–	1	85058-60108
Offset open –m–	1	85058-60109
Offset open –f–	1	85058-60110
Lowband load –m–	1	85058-60128 85058-60111 ^c
Lowband load –f–	1	85058-60129 85058-60112 ^c
Adapters (1.85 mm)^a		
Adapter m–m	1	85058-60113
Adapter f–f	1	85058-60114
Adapter m–f	1	85058-60115
Calibration Kit Storage Case		
Box	1	5180-8419
Foam (top)	1	5181-5542
Foam (bottom)	1	85058-80014
Wrenches		
5/16 in., 90 N–cm (8 in–lb) torque wrench	1	8710-1765
8 mm open–end wrench	1	8710-2466
Miscellaneous Items		
2.4 mm female gage set (also used for 1.85 mm)	1	11752-60107
2.4 mm male gage set (also used for 1.85 mm)	1	11752-60108
User’s and service guide	1	85058-90005 ^d

Table 6-1 Replaceable Parts for the 85058B (Standard) Calibration Kit

Description	Qty Per Kit	Keysight Part Number
10x Magnifying Glass	1	1000-1114
Protective end caps (male)	as required	1401-0208
Protective end caps (female)	as required	1401-0202

- a. See [“Clarifying the Terminology of a Connector Interface” on page 1-20.](#)
- b. Refer to [“How to Identify Devices” on page 1-4.](#)
- c. Part numbers in *italic* typeface are for production assemblies and cannot be ordered by customers. Both the replacement part number and the production part number are interchangeable and have identical performance.
- d. See [“Printing Copies of Documentation from the Web” on page iii.](#)

Figure 6-1 Replaceable Parts for the 85058B (Standard) Calibration Kit

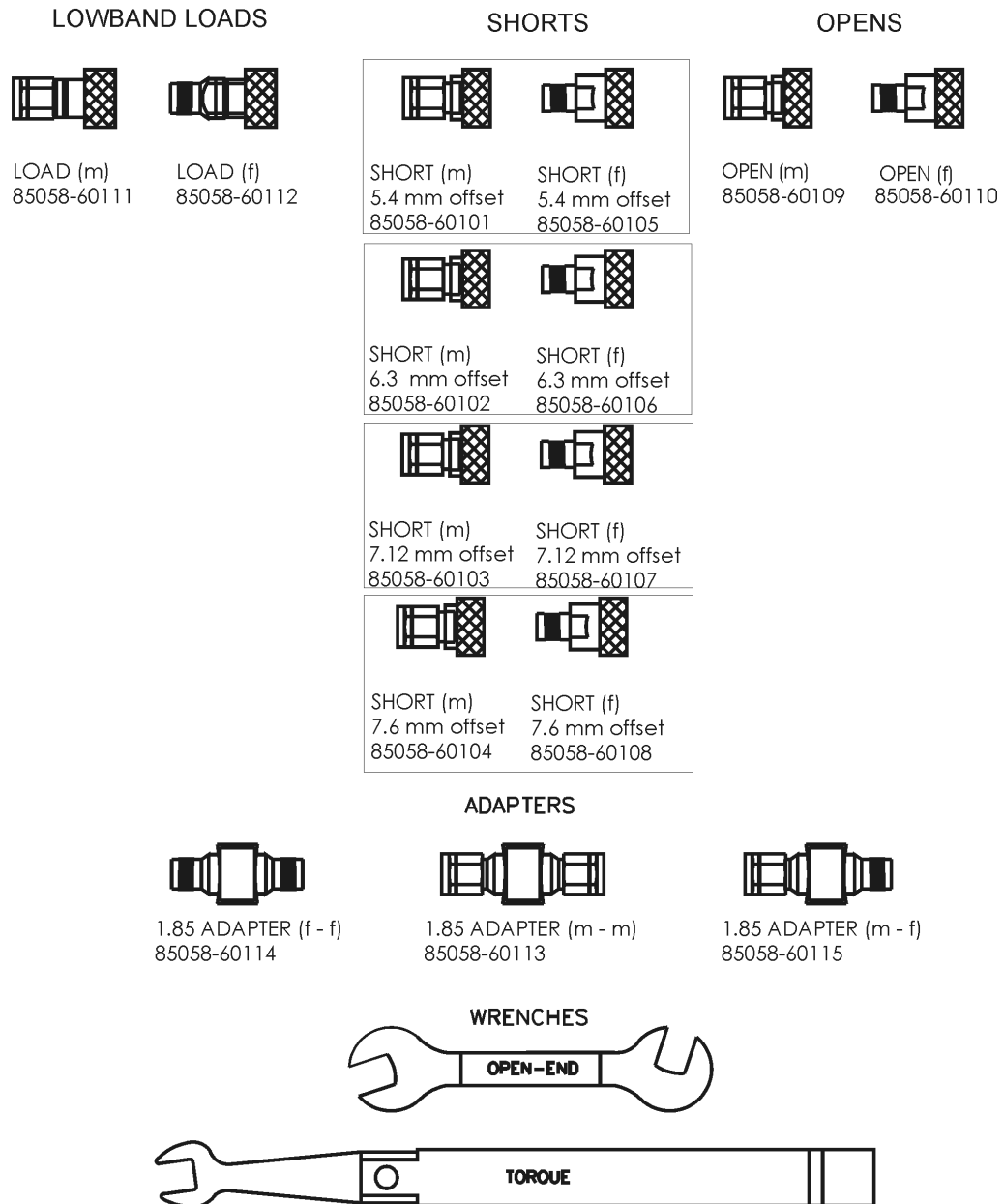

- Not Shown:
- * Storage case
 - * Female gage set
 - * Male gage set
 - * Protective end caps
 - * User's and Service Guide
 - * 10x magnifying glass

Table 6-2 Replaceable Parts for the 85058E (Economy) Calibration Kit

Description	Qty Per Kit	Keysight Part Number
Calibration Devices (1.85 mm)^{a,b}		
5.4 mm offset short –m–	1	85058-60101
5.4 mm offset short –f–	1	85058-60105
Offset open –m–	1	85058-60109
Offset open –f–	1	85058-60110
Broadband termination –m–	1	85058-60130 <i>85058-60123^c</i>
Broadband termination –f–	1	85058-60131 <i>85058-60124^c</i>
Adapters (1.85 mm)^a		
Adapter m–m	1	85058-60113
Adapter f–f	1	85058-60114
Adapter m–f	1	85058-60115
Calibration Kit Storage Case		
Box	1	5180-7862
Foam (top)	1	5180-8428
Foam (bottom)	1	85058-80015
Wrenches		
5/16 in., 90 N–cm (8 in–lb) torque wrench	1	8710-1765
8 mm open–end wrench	1	8710-2466
Miscellaneous Items		
User’s and service guide	1	85058-90005 ^d
Protective end caps (male)	as required	1401-0208
Protective end caps (female)	as required	1401-0202

a. See “Clarifying the Terminology of a Connector Interface” on page 1-20.

b. Refer to “How to Identify Devices” on page 1-4.

c. Part numbers in *italic* typeface are for production assemblies and cannot be ordered by customers. Both the replacement part number and the production part number are interchangeable and have identical performance.

d. See “Printing Copies of Documentation from the Web” on page iii.

Figure 6-2 Replaceable Parts for the 85058E (Economy) Calibration Kit

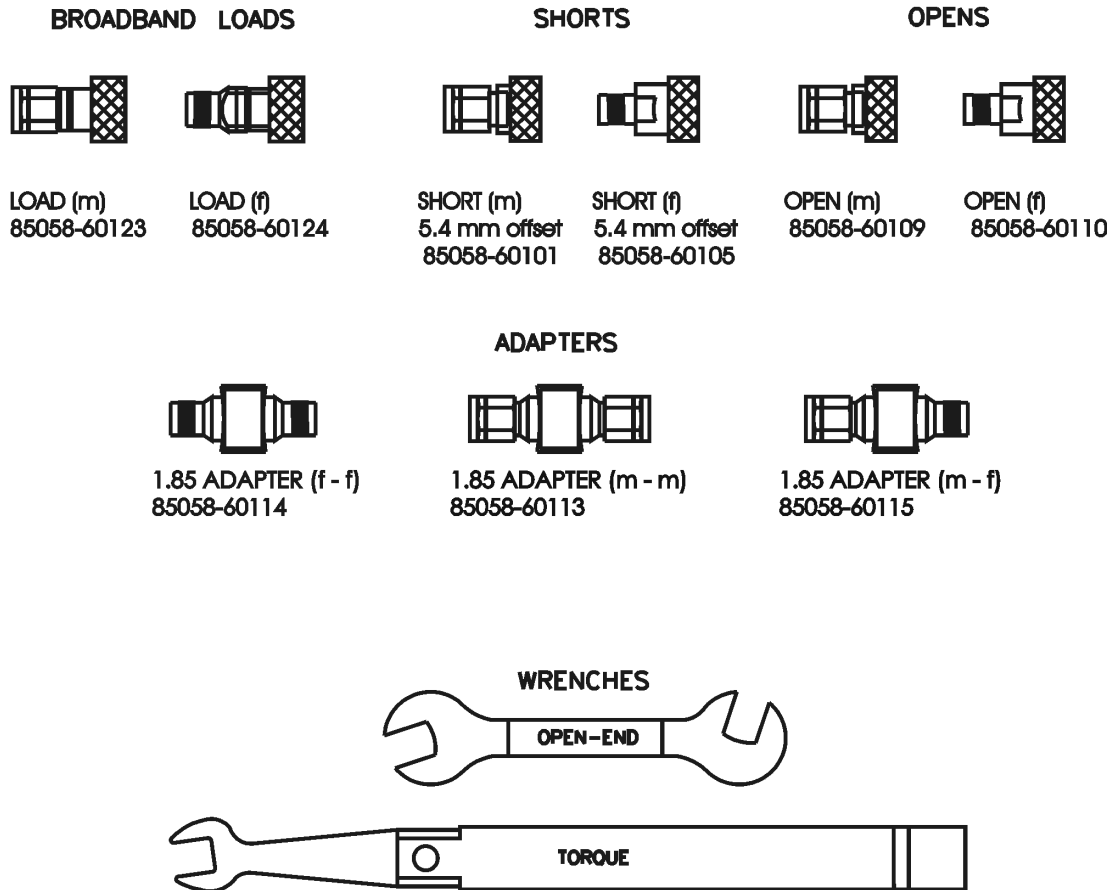

Not Shown:
* Storage case
* User's and Service Guide
* Protective end caps

Table 6-3 Items Not Included in the Calibration Kits

Description	Qty	Keysight Part Number
Adapters^a (50Ω)		
U-band waveguide to 1.85mm –f– coax	1	U281A
U-band waveguide to 1.85mm –m– coax	1	U281B
V-band waveguide to 1.85mm –f– coax	1	V281A
V-band waveguide to 1.85mm –m– coax	1	V281B
1mm –m– to 1.85mm –m–	1	11921E
1mm –f– to 1.85mm –f–	1	11921F
1mm –m– to 1.85mm –f–	1	11921G
1mm –f– to 1.85mm –m–	1	11921H
Adapter set: 1.85mm –f ^b – to 1.85mm –f– 1.85mm –f ^b – to 1.85mm –m ^b –	1 set	85130H
Adapter anti-rotation clamp (Two clamps are required for use with the 85130H adapter set.)	1	85130-60016
ESD Protective Devices		
Grounding wrist strap	1	9300-1367
5 ft grounding cord for wrist strap	1	9300-0980
2 ft by 4 ft conductive table mat with 15 ft grounding wire	1	9300-0797
ESD heel strap	1	9300-1308
Connector Cleaning Supplies		
Anhydrous isopropyl alcohol (>92% pure) ^c	--	--
Foam tipped cleaning swabs	100	9301-1243
The following items are included in the 85058B (Standard) kit but NOT in the 85058E (Economy) kit.		
2.4 mm female gage set (also used for 1.85 mm)	1	11752-60107
2.4 mm male gage set (also used for 1.85 mm)	1	11752-60108
10x Magnifying Glass	1	1000-1114

a. See ["Clarifying the Terminology of a Connector Interface"](#) on page 1-20.

b. Ruggedized connector.

c. Keysight can no longer safely ship isopropyl alcohol, so customers should purchase it locally.

A Standard Definitions

Class Assignments and Standard Definitions Values are Available on the Web

Class assignments and standard definitions may change as more accurate model and calibration methods are developed. You can download the most recent class assignments and standard definitions from Keysight's Calibration Kit Definitions Web page at <http://na.support.keysight.com/pna/caldefs/stddefs.html>.

For a detailed discussion of calibration kits, refer to the Keysight Application Note, "Specifying Calibration Standards and Kits for Keysight Vector Network Analyzers." This application note covers calibration standard definitions, calibration kit content and its structure requirements for Keysight vector network analyzers. It also provides some examples of how to set up a new calibration kit and how to modify an existing calibration kit definition file. To download a free copy, go to www.keysight.com and enter literature number 5989-4840EN in the Search window.

Numerics

85058B and 85058BP, 1-2
 85058E and 85058EP, 1-2
 8510 network analyzer, 1-6

A

adapters, 1-5, 1-6
 part numbers, 6-8
 alcohol, isopropyl, as cleaning solvent, 3-6

B

bands that identify devices, 1-4
 broadband calibration technique
 85058E, 1-4
 broadband SOLT
 calibration standards, 1-8
 calibration technique, 1-8
 broadband terminations, 1-5

C

cal kit
 contents, 1-4
 overview, 1-2
 serial number, 1-17
 calibration
 1-Port, 85058B cal kit, 1-9
 1-Port, 85058E cal kit, 1-10
 2-Port, 85058B cal kit, 1-11
 2-Port, 85058E cal kit, 1-12
 bad, 5-2
 broadband SOLT technique, 85058E, 1-8
 certificate of, 4-2
 definitions, 1-6
 devices
 85058B, 6-3
 85058E, 6-6
 frequency, 1-21
 offset-short technique, 85058B, 1-8
 temperature, 2-2
 when to perform, 1-21
 calibration definitions
 entering, 1-6
 permanently stored, 1-6
 calibration error
 specifications
 85058B Data-Based.ckt, 1-13
 85058E Data-Based.ckt, 1-15
 calibration kit
 Keysight Application Note, A-2
 contents, 1-4
 modifying definition files, A-2
 overview, 1-2
 serial number, 1-17
 calibration kit labels
 85058B cal kit, 1-7
 85058E cal kit, 1-8
 calibration report, 4-2
 calibration sticker, 4-3
 calibration technique

 85058B, 1-3
 85058E, 1-4
 certificate of calibration, 4-2
 certification, specifications, 2-9
 characteristics
 mechanical, 2-3
 supplemental, 2-3
 class assignments
 downloading from Keysight Web site, A-2
 cleaning connectors, 3-6
 cleaning supplies, 1-6
 ordering, 6-8
 part numbers, 6-8
 compressed air or nitrogen, 3-6
 conductor
 mating plane, 2-3
 connections, 3-2, 3-14, 3-16
 cautions in making, 3-14
 disconnecting, 3-16
 ESD concerns, 3-14
 final, 3-14
 how to make, 3-14
 preliminary, 3-14
 undoing, 3-16
 using a torque wrench, 3-14
 connector
 cleaning, 3-6
 cleaning supplies, 6-8
 damage, 3-3
 female, 3-5, 3-12
 gaging, 3-8
 when to do, 3-9
 life, 3-3
 male, 3-10
 mating plane, 3-6
 terminology, 1-20
 threads, 3-6
 visual inspection, 3-3
 wear, 3-3
 connector contacts
 concentricity, 3-4
 integrity, 3-4
 connector gage
 handling, 3-10, 3-12
 zeroing, 3-10, 3-12
 connector gage accuracy, 3-8
 connectors, slotted, 1-19
 contacting Keysight, 5-5
 contents
 kit, 1-4

D

damage
 to connectors, 3-3
 damage, shipment, 1-16
 damaged connectors, 3-3
 data, recertification, 4-2
 data-based model, 1-2
 defective connectors, 3-3
 defining calibration standards, two models, 1-2

Index

definitions

- calibration, 1-6
 - entering, 1-6
 - permanently stored, 1-6
- deviation from nominal phase, 85058B, 2-5
- deviation from nominal phase, 85058E, 2-8

device

- conductor
 - mating plane, 2-3
- connecting, 3-14
- disconnecting, 3-16
- handling, 3-16
- maintenance, 1-20
- part numbers, 6-8
- pin depth, 2-3
- storage, 3-16
- temperature, 2-2
- visual inspection, 3-3

devices

- how Keysight verifies, 4-2
- serial numbers, 1-17

dimensions

- device
 - center conductor, 2-3
 - outer conductor, 2-3

disconnections, 3-16

documentation warranty, 1-ii

downloading class assignments & std definitions from the Web, A-2

E

- electrical specifications, 85058B, 2-5
- electrical specifications, 85058E, 2-8
- electrostatic discharge, 3-2
- supplies

- part numbers, 6-8

- when making connections, 3-14

environmental requirements, 2-2

equipment

- required, 1-6
- required but not supplied, 1-6
- supplied, 1-4, 6-2, 6-3, 6-6

error specifications

calibration

- 85058B Data-Based.ckt, 1-13
- 85058E Data-Based.ckt, 1-15

ESD, 3-2

- precautions, 3-2, 3-6
- protection devices, 1-6
- supplies
 - part numbers, 6-8
- when making connections, 3-14

expanded math, 1-3

F

frequency

- performance, 1-7
- range, 85058B, 2-5
- range, 85058E, 2-8
- specifications, 85058B, 2-5

- specifications, 85058E, 2-8
- frequency of calibration, 1-21

G

gage

- connector
 - handling, 3-10, 3-12
 - master, 6-8
- zeroing, 3-10, 3-12

gage master

- part numbers, 6-8

gages, 1-6

gaging

- female connectors, 3-12
- male connectors, 3-10
- gaging connectors, 3-8
 - when to do, 3-9

H

- handling, 3-16
- how often to calibrate, 1-21
- how to identify calibration devices, 1-4
- humidity, 2-2

I

- identifying shorts, opens, & loads, 1-4
- incoming inspection, 1-16
- information, troubleshooting, 5-3
- inspection
 - damage, 3-3
 - defects, 3-3
 - female connectors, 3-5
 - incoming, 1-16
 - mating plane, 3-5
 - visual, 3-3
- isopropyl alcohol, as cleaning solvent, 3-6

K

- Keysight Technologies
 - application note, A-2
 - contacting, 5-5

kit

- contents, 1-4
- overview, 1-2
- serial number, 1-17

L

- label
 - calibration, 4-3
- loads
 - lowband, 1-4
- lowband loads, 1-4

M

- maintenance, 3-2
 - preventive, 1-20
- maintenance of devices, 1-20
- making connections, 3-14
- manual

- part number, 6-3, 6-6
- math, expanded, 1-3
- mating plane
 - conductor, 2-3
 - connector, 3-6
 - inspection, 3-5
 - surfaces, 3-7
- mechanical characteristics, 2-3
- mechanical integrity, 2-3
- models for defining calibration standards, 1-2
- modifying calibration kit definition files, A-2

N

- network analyzer, 8510, 1-6
- nitrogen, 3-6
- numbers, serial, recording, 1-17

O

- offset opens, 1-4, 1-6
- offset short calibration technique, 85058B, 1-3
- offset shorts, 1-4, 1-6
- offset-short
 - calibration standards, 1-7
 - calibration technique, 1-7
- open-end wrench, 3-16
 - part number, 6-3, 6-6
- opens, 1-4, 1-6
- ordering parts, 6-2

P

- part numbers, 6-2
- parts
 - ordering, 6-2
 - replaceable, 6-2
 - required but not supplied, 6-8
- performance verification, 4-2
 - fail, 5-2
- pin depth, 2-3
 - affect on electrical performance, 2-4
 - definition of, 2-3
 - effect on electrical specifications, 2-4
 - importance of, 2-4
 - observed limits, 2-4
 - protrusion, 2-3
 - recession, 2-3
 - typical values, 2-4
- Polynomial model, 1-3
- preventive maintenance, 1-20
- protrusion
 - pin depth, 2-3

R

- recertification, 4-3
 - how often?, 4-3
 - interval, 4-3
 - what's included, 4-3
 - where to send your kit, 4-3
- recession
 - pin depth, 2-3

- regulations
 - environmental, 3-6
- replaceable parts, 6-2
- requirements
 - environmental, 2-2
- return
 - kit or device to Keysight, 5-4
- return loss
 - specifications, 85058B, 2-5
 - specifications, 85058E, 2-8
- rings that identify devices, 1-4

S

- serial numbers, recording, 1-17
- service, 5-2, 5-4
- service tag, 1-16, 4-3, 5-4
- shipment
 - damage, 1-16
 - verifying complete, 1-16
- shorts, 1-4, 1-6
- slotted connectors, 1-19
- SOLT broadband calibration, 1-8
- specifications, 2-2
 - calibration errors
 - 85058E Data-Based.ckt, 1-15
 - certification, 2-9
 - electrical, 85058B, 2-5
 - electrical, 85058E, 2-8
 - environmental, 2-2
 - frequency, 85058B, 2-5
 - frequency, 85058E, 2-8
 - humidity, 2-2
 - pin depth, 2-4
 - return loss, 85058B, 2-5
 - return loss, 85058E, 2-8
 - temperature, 2-2
 - verifying, 4-2
- specified frequency performance, 1-7
- standard definitions
 - downloading from Keysight Web site, A-2
- standards
 - NIST, 2-9, 4-3
- static discharge, 3-2
- sticker
 - calibration, 4-3
- storage, 3-16
 - temperature, 2-2
- supplemental characteristics, 2-3
- supplies
 - cleaning, 1-6

T

- tag
 - service, 4-3, 5-4
- tag, service, 1-16
- temperature
 - calibration, 2-2
 - device, 2-2
 - error-corrected temperature range, 2-2
 - measurement, 2-2

Index

- operating range, 2-2
- verification and measurement, 2-2
- terminations, broadband, 1-5
- terminology, connector, 1-20
- test data, 4-2
- threads
 - connector, 3-6
- torque wrench, 3-14
 - part number, 6-3, 6-6
 - specifications, 3-14
- traceability, 4-2
- troubleshooting, 5-2

V

- verification
 - performance, 4-2
 - temperature, 2-2
- visual inspection, 3-3

W

- warranty, documentation, 1-ii
- when to calibrate, 1-21
- wrench
 - open-end, 3-16
 - part number, 6-3, 6-6
 - undoing connections, 3-16
 - torque
 - part number, 6-3, 6-6
- wrenches
 - part numbers, 6-3, 6-6

Z

- zeroing
 - connector gage, 3-10, 3-12



This information is subject to change without notice.
© Keysight Technologies 2003 - 2015
Edition 1 May 2015
Printed in Malaysia



85058-90005