



PIM Hunter™

Passive Intermodulation Probe



Passive Intermodulation (PIM)

Passive intermodulation (PIM) is a well-known problem in cellular systems. Downlink signals at the cell site mix at passive, non-linear junctions in the RF path, creating new signals. If these new signals (intermodulation products) fall in an operator's uplink band, they can elevate the noise floor and degrade system performance.

The PIM Hunter tool, a passive intermodulation test probe, helps field technicians more quickly discover the precise location of external PIM sources at cell sites. Designed for use with Anritsu's PIM Master™ and handheld spectrum analyzers, the PIM Hunter test probe enables field professionals to use traditional interference hunting techniques to accurately locate external PIM sources for optimum wireless network performance.

It complements Anritsu's patented Distance-to-PIM™ (DTP) technology that determines the distance between the antenna and external PIM. A technician can walk along the arc of that distance with PIM Hunter tool to detect the exact source of the external PIM.

Key Features

- Pinpoint External PIM (outside the antenna system)
- PIM Hunter solution is a specialized antenna to identify intermodulation products from 600 to 2700 MHz
- Operates with the Spectrum Master™ MS2720T or BTS Master™ MT8220T in burst detect sweep mode and bandpass filter
- Operates with Spectrum Master MS2712E or MS2713E, Cell Master™ MT8212E or MT8213E, and Site Master™ S332E or S362E with custom settings and bandpass filter
- PIM Master™ is required to generate the primary test tones to generate IM products for the PIM Hunter to locate
- Fiberglass extension rod
- Molded ABS probe cover
- Times Microwave TuffGrip® rubber handle
- Type N, female RF connector



PIM Hunter has been custom designed to support external PIM identification over the 600 MHz to 2700 MHz frequency range.



PIM Hunter

Passive Intermodulation Probe

Pinpointing external PIM beyond the antenna

PIM Hunter is a patent-pending technology that allows a test technician to identify the location of external PIM beyond the antenna. By walking along the arc of the DTP distance from the antenna with PIM Hunter, the technician can pinpoint the source of the PIM typically within a few centimeters.

Hunting External PIM

The PIM hunting process begins with an Anritsu PIM Master device to inject two high power test signals into the system under test. The test signals broadcast through the site antenna, exciting any PIM sources in the RF path. These PIM sources behave like CW transmitters radiating the IM3 frequency in all directions. With the PIM Hunter test probe connected to a spectrum analyzer in burst detect mode (Spectrum Master MS2720T or BTS Master MT8220T) or in custom setting (Spectrum Master MS2712E/MS2713E, Site Master S332E/S362E, Cell Master MT8212E/MT8213E) and an appropriate band-pass filter installed, technicians can "hunt" for these IM3 signal sources along the arc of the distance provided by the DTP measurement of the PIM Master device. When the probe tip comes in close proximity to a PIM source, the PIM value increases by as much as 30 dB, indicating the precise location of the PIM source.

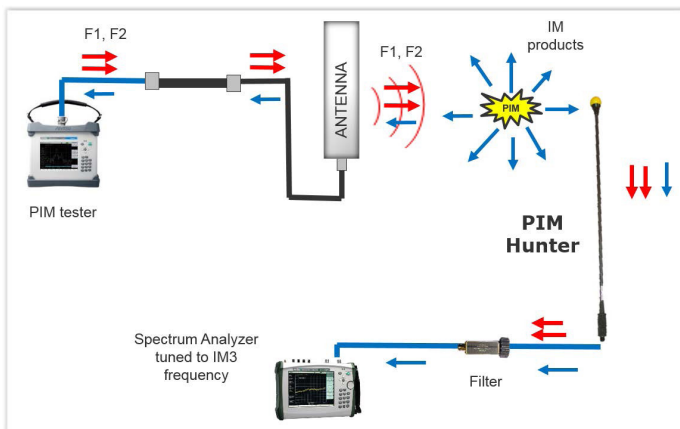

External PIM hunting process

Correcting PIM

The PIM analyzer serves multiple purposes in the external PIM identification and remediation process. It first acts as the high-power signal source enabling the PIM Hunter tool to precisely identify external PIM locations. It also performs the pass / fail measurement necessary to document whether or not fixes, both permanent as well as temporary, will meet system requirements.

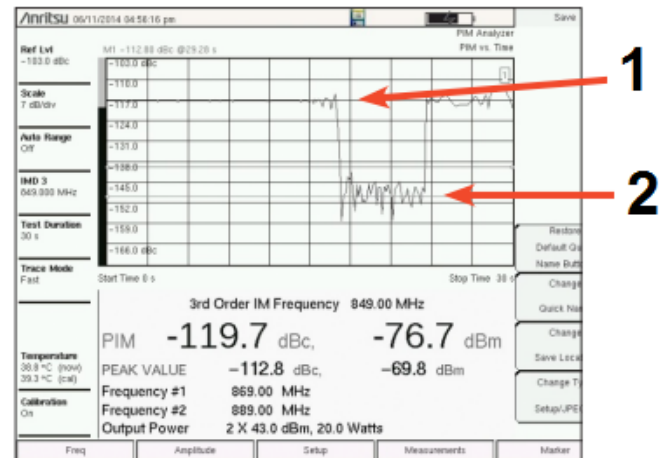

- 1 - PIM level before delaying temporary fix
- 2 - PIM level able to be achieved with temporary fix deployed (30 dB reduction)

Learn more at: www.anritsu.com

