

Solutions for Exploring Phase Noise Measurement Methods and Techniques

Introduction

The process of extracting signals from noise is a challenge faced by many engineers working with RF and microwave technologies. Those who are developing cutting-edge radar and communication systems often use extreme amounts of processing to extract maximum information from faint or impaired signals.

Phase noise is often the nemesis that limits the performance of a receiving system. For example, phase noise degrades the ability to process Doppler information in a pulse-based radar system and degrades error vector magnitude (EVM) performance in a digitally modulated communication system.

Measuring phase noise can often seem like a puzzle with many oddly shaped pieces that are difficult to connect. Even with today's advanced hardware and improved techniques, the process of making measurements and interpreting the results may still contain a certain amount of mystery. To help unravel the puzzle, this application note provides a heuristic overview of phase noise fundamentals before describing the three most common measurement techniques and where they apply.

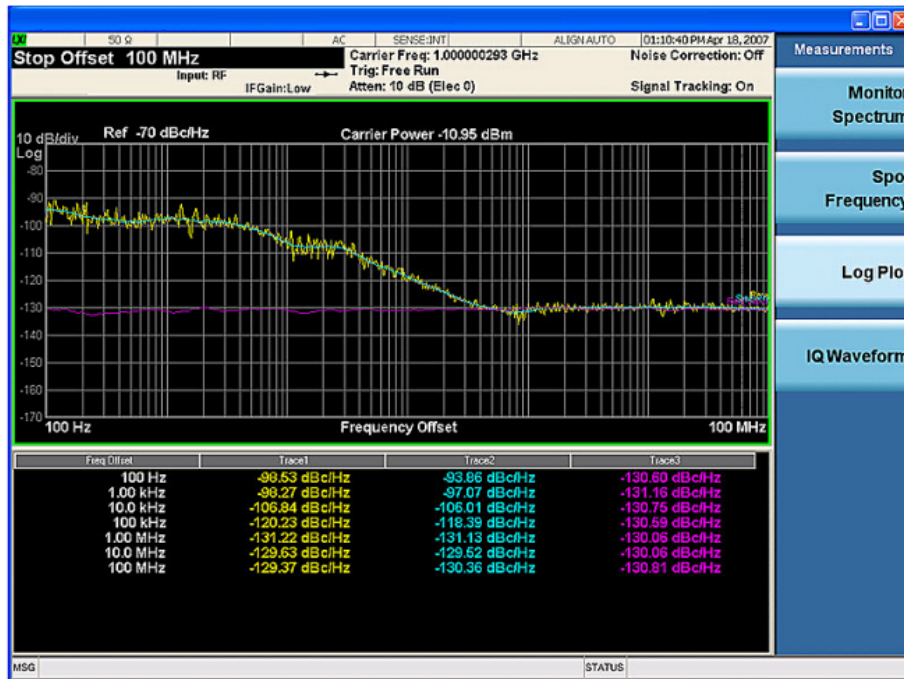

The Foundation

Stability and noise

Any discussion of phase noise is mostly concerned with the frequency stability of a signal. Long-term stability, perhaps of an oscillator, may be characterized in terms of hours, days, months, or even years. Short-term stability refers to frequency changes that occur over a period of a few seconds or less. These short-cycle variations have a much greater effect on systems that rely on extreme processing to extract more information from a signal. For that reason, this discussion will focus on short-term stability.

Short-term stability can be described in many ways but the most common is single-sideband (SSB) phase noise. The US National Institute of Standards and Technology (NIST) defines SSB phase noise as the ratio of two power quantities: the power density at a specific frequency offset from the carrier and the total power of the carrier signal. This is most commonly measured in a 1-Hz bandwidth at a frequency “f” away from the carrier and the units are dBc/Hz or “decibels below carrier frequency power over a 1-Hz bandwidth.”

The level of phase noise is deterministically related to the carrier frequency, increasing by 6 dB for every doubling in frequency. When characterizing the performance of components integrated into advanced radar and communication systems, measurements of phase noise for a 1 GHz carrier may extend from roughly -40 dBc/Hz at “close to the carrier” offsets (1 kHz or less) down to -150 dBc/Hz at “far from the carrier” offsets (10 MHz or more). These measurements will be about 18 dB higher with a carrier frequency of 8 GHz.

At such low levels, the measurement noise floor is affected by two microscopic electronic effects: thermal noise from passive devices, which is broad and flat (white noise); and flicker noise from active devices, which has a $1/f$ shape (pink noise) that emerges from the thermal noise at lower offsets. Both of these contributors are unavoidable because they are present all along the signal chain: in the measuring instrument, in the device that produces the signal-under-test (SUT), and even in the cables that connect the two.

Another sometimes overlooked source of noise is any type of amplifier in the signal chain. While the main purpose is to increase the power level of a weak carrier signal, the amplifier adds its own noise and also boosts any input noise. The net effect: amplifier, thermal and flicker noise combine to give any phase noise plot a characteristic shape and, more significantly, reduce the theoretical lower limit of any phase noise measurement (Figure 1).

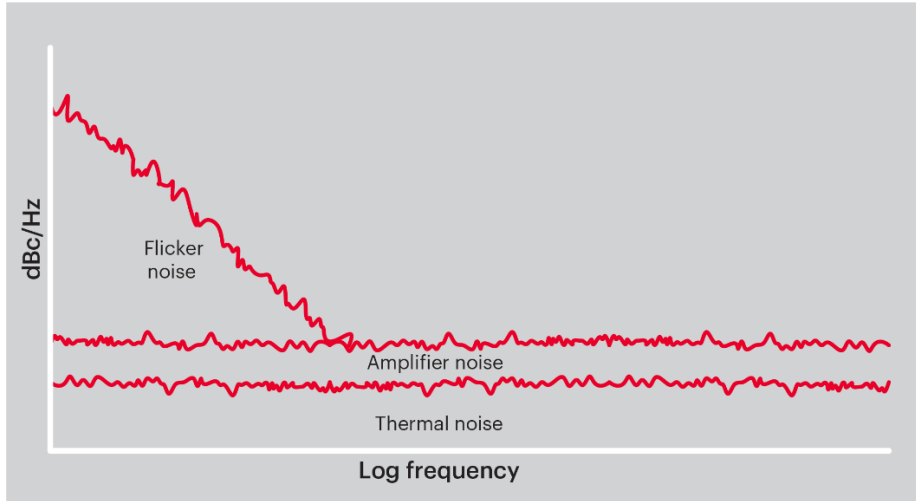

Figure 1. The three main contributors to noise create a theoretical lower limit for phase noise measurements.

These effects all show up in the phase noise characteristics of a high-performance signal generator. For example, the underlying sources of noise can be traced back to the major sections of the instrument block diagram (Figure 2). For offsets below 1 kHz, the noise is dominated by the performance of the reference oscillator, which is multiplied up to the carrier frequency. The other major contributors are the synthesizer at offsets of 1 kHz to roughly 100 kHz, the yttrium iron garnet (YIG) oscillator from 100 kHz to 2 MHz, and the output amplifier at offsets above 2 MHz. When these effects are well understood, they can be minimized and optimized within a system design to ensure maximum performance.

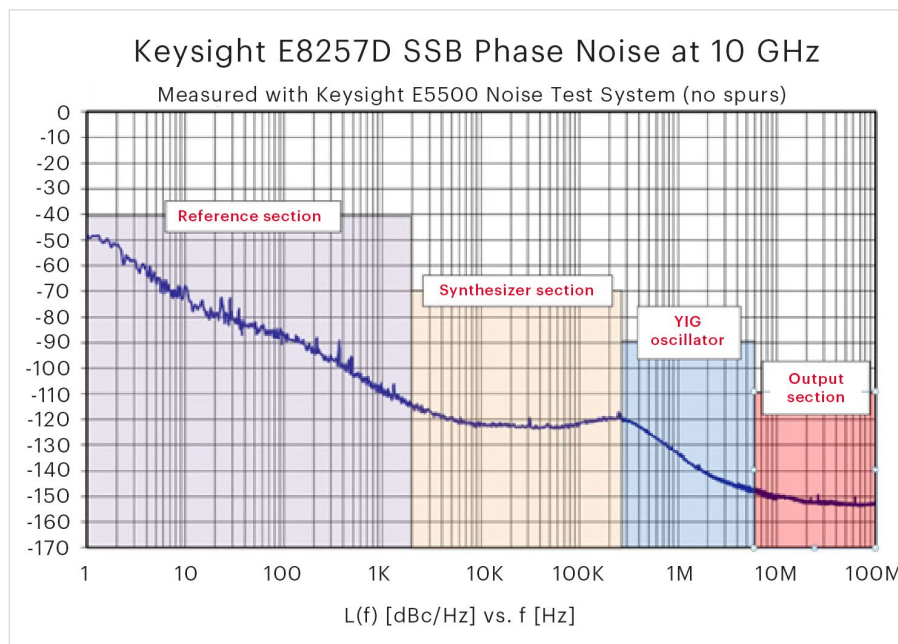

Figure 2. Contributions to the phase noise performance of a signal generator can be traced to the major sections of its internal architecture.

The Measurements

Three approaches

Phase noise measurement techniques have evolved along with advances in spectrum analyzer technology. This section focuses on three methods that range from basic to intermediate complexity: direct-spectrum measurements, phase-detector techniques and two-channel cross-correlation. The section that follows compares measurement solutions capable of implementing one or more of these methods.

Direct-spectrum method

The direct-spectrum approach is the oldest and perhaps simplest way to measure phase noise. The SUT or device-under-test (DUT) is simply connected to the input of a signal analyzer such as the Keysight Technologies, Inc. PXA and the analyzer is then tuned to the carrier frequency. Next, two measurements are made: the power of the carrier and the power spectral density (PSD) of the oscillator noise at a specified offset frequency and referenced to the carrier power.

As is often the case with a simple approach, a variety of corrections must be applied to ensure an accurate result. For example, it may be necessary to correct for the noise bandwidth of the analyzer's resolution bandwidth (RBW) filters. In addition, it may be necessary to also correct for the behavior of the analyzer's peak detector, which may under-report the actual noise power.

It was once necessary to perform these corrections manually, and Keysight Application Note (publication number 5952-0292), Spectrum Analyzer Basics, is a useful resource. Today, these extra steps are no longer necessary when using a signal analyzer equipped with either an interval-band/interval-density marker function (for the PSD measurement) or a built-in capability such as the Keysight N9068A phase noise measurement application for the PXA, MXA and EXA signal analyzers.

Time and experience have revealed the potential limitations of the direct-spectrum method. Most are related to shortcomings in the quality or performance of some spectrum analyzers: residual FM of the analyzer's local oscillator (LO), the noise sidebands or phase noise of the analyzer LO, and the analyzer noise floor can all affect the results. In addition, most spectrum analyzers measure only the scalar magnitude of the SUT noise sidebands. As a result, the analyzer is unable to differentiate between amplitude noise and phase noise. Finally, the process is complicated by the need to make a noise measurement at every frequency offset of interest—and this is may be a very time-consuming task when performed manually.

Phase-detector techniques

A phase detector can be used to separate phase noise from amplitude noise. As illustrated in Figure 3, the phase detector converts the phase difference of two input signals into a voltage at the output of the detector. When the phase difference is set to quadrature, the voltage will be zero. Any phase fluctuation from quadrature will result in a corresponding voltage fluctuation at the output.

This concept is the basis of several commonly used phase noise measurement techniques. Three are of particular interest here: the reference-source/phase-locked loop (PLL) method, the frequency-discriminator method and the heterodyne digital discriminator method.

Reference-source/PLL method

An adaptation of the phase-detector technique, the reference-source/PLL method uses a double-balanced mixer as the detector and the inputs are the reference source and the SUT (Figure 4). A reference source such as a Keysight PSG or MXG signal generator is controlled such that it follows the SUT at the same carrier frequency but with a 90-degree phase offset. To ensure accurate measurements of the SUT, the phase noise of the reference source should be either negligible or well-characterized.

The mixer sum frequency is removed with a low-pass filter and the difference frequency is 0 Hz with an average output of 0 V (DC). Riding on top of the DC voltage are any AC voltage fluctuations, and these are proportional to the combined noise contributions of the two input signals. This baseband signal is often boosted by a low-noise amplifier (LNA) before being input to the signal analyzer.

This method yields the overall best sensitivity and the widest measurement coverage, with a frequency-offset range that spans 0.1 Hz to 100 MHz. It's also insensitive to AM noise and is capable of tracking drifting sources.

There are two potential issues. First, the reference source must have low phase noise while also being electronically tunable. Second, if the SUT has a high drift rate, then the reference source must be tunable over a very wide range.

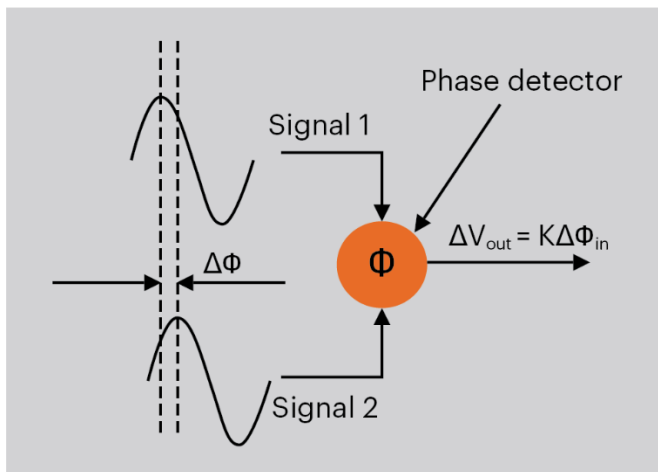

Figure 3. This basic phase-detector concept has been implemented in many ways.

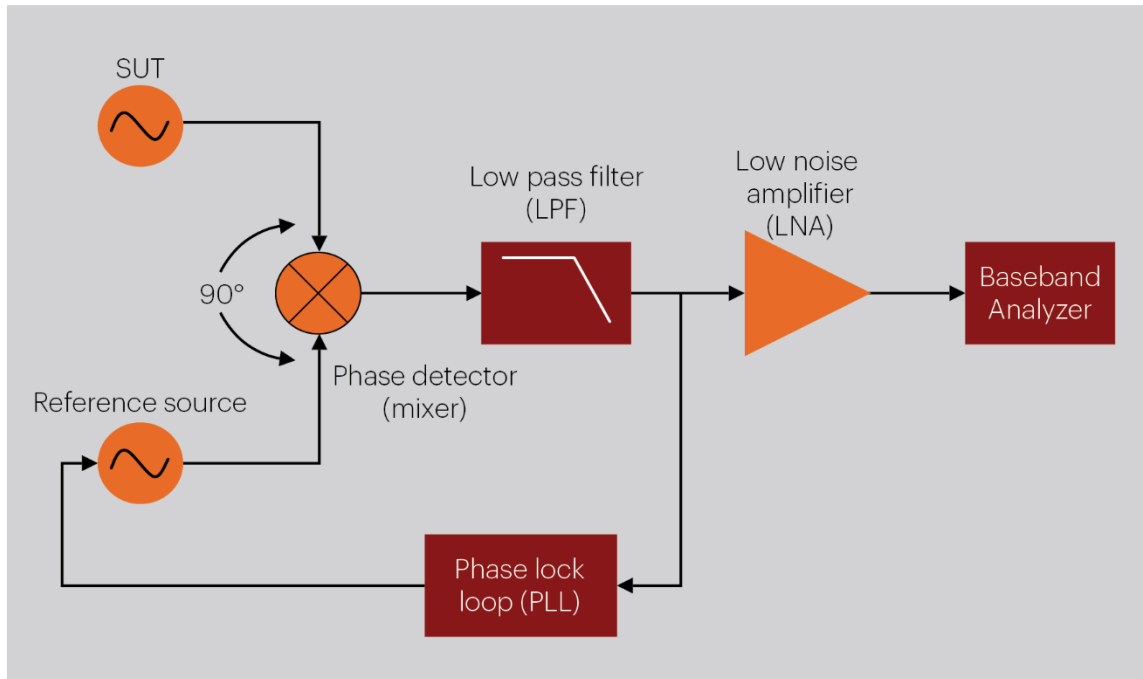

Figure 4. This method uses a reference source and a double-balanced mixer as the basis of the phase detector.

Frequency-discriminator method

To simplify equipment configuration and the measurement process, this method eliminates the reference source by substituting an analog delay line. As shown in Figure 5, the SUT is split into two channels. One path is delayed relative to the other and the delay line converts frequency variations into phase fluctuations. Adjusting the delay time will determine the phase quadrature of the two inputs to the mixer. Next, the phase detector converts the phase fluctuations into voltage variations that the signal analyzer measures as frequency noise. The frequency noise is then converted to a phase noise reading for the SUT.

One drawback of this method is a decrease in measurement sensitivity, especially at close-in offset frequencies. A longer delay line will provide improved sensitivity; however, it can reduce the signal-to-noise ratio and limit the maximum measurable offset frequency. In addition, the insertion loss of the delay line may be too great for the SUT output level to overcome.

From the foregoing, this method works best with free-running sources such as inductor/capacitor (LC) oscillators and cavity oscillators. These tend to produce noisy signals that have high-level, low-rate phase noise or high close-in spurious sideband conditions that can limit the performance of the PLL technique.

Heterodyne digital discriminator method

Today's technology makes it possible to replace the analog delay line with a heterodyne digital discriminator. Referring to Figure 6, the SUT is downconverted to an intermediate frequency (IF) by a mixer and a frequency-locked LO. The IF signal is first amplified and digitized and then split and delayed using digital signal processing (DSP). As in the preceding method, the delayed version of the signal is compared to the non-delayed version using a digital mixer and the delay is adjusted to achieve quadrature. The mixer output is filtered to remove the sum component, leaving a baseband component that is processed to produce a phase noise value.

This method is well-suited to measurements of the relatively large phase noise present in oscillators and unstable signal sources. It provides a wider measurement range than the PLL method and eliminates the need to reconnect the analog delay lines used in the frequency-discriminator method. By setting the delay time to zero, the heterodyne method also enables easy and accurate measurements of AM noise with the same setup and RF connections.

On the downside, the total dynamic range of the measurement is limited by the LNA and the analog-to-digital converters (ADCs). The next method solves that problem.

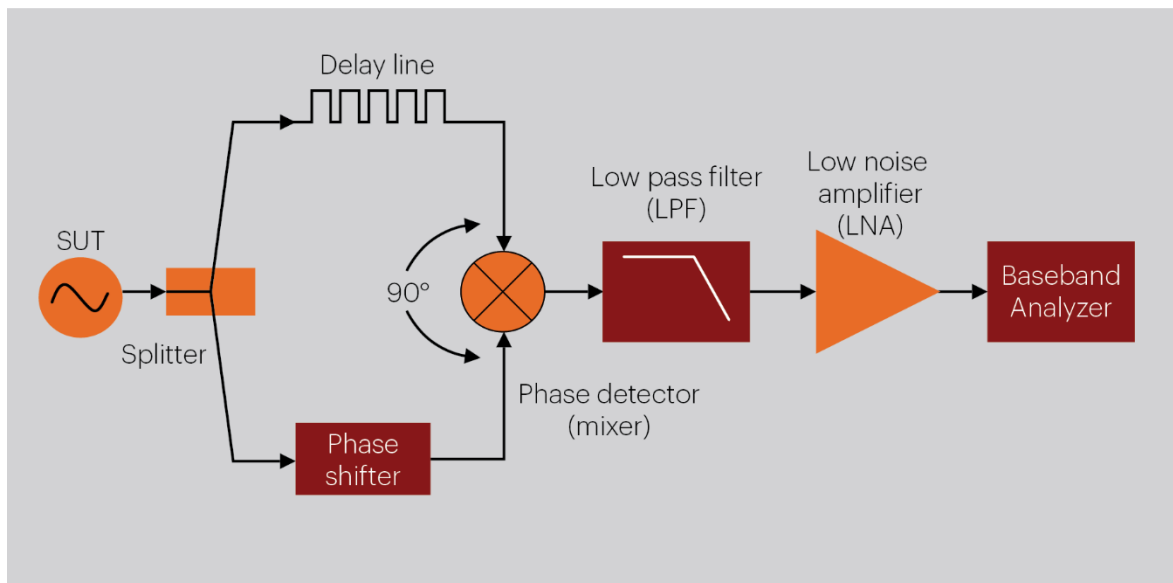

Figure 5. Splitting the SUT and manipulating it with a delay line and phase shifter eliminates the need for reference source.

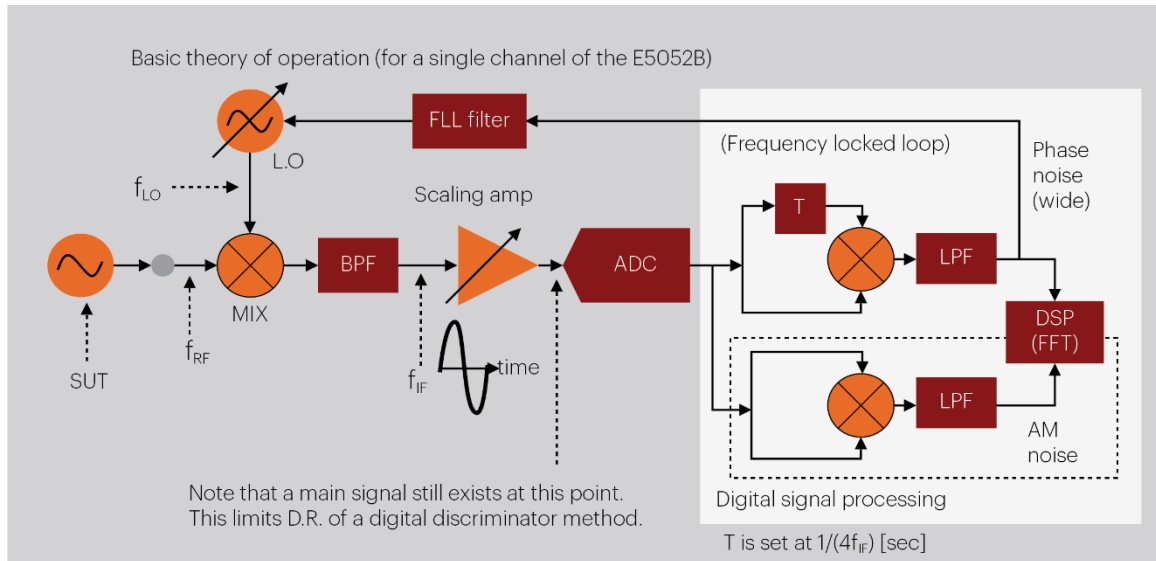

Figure 6. Digital technology makes it possible to mimic the behavior of the analog delay line and produce accurate phase noise measurements.

Two-channel cross-correlation method

Within a measuring instrument such as the Keysight E5052B signal source analyzer (SSA), this approach uses two duplicate reference-source/PLL channels and calculates the cross-correlation between the two resulting outputs (Figure 7). Because any SUT noise present in both channels is coherent, it is not affected by the cross-correlation computation. In contrast, any internal noise generated by either channel is non-coherent and therefore diminished in the cross-correlation operation by the square root of the number of correlations. The number of correlation operations is a key factor in total measurement time. In the E5052B, the number of correlation operations is a user-selected value. Increasing the number of correlations reduces the noise contribution from both channels (Table 1) but extends the time required to complete the measurement.

Because the two-channel technique reduces measurement noise, it provides superior measurement sensitivity and, because it relies on DSP capabilities, it enhances sensitivity without requiring exceptional performance in the measurement hardware. This method also provides greater dynamic range than the digital discriminator method described above.

With these benefits, the two-channel cross-correlation method is an especially good choice when characterizing free-running oscillators. As a general observation, it provides excellent phase noise performance when measuring many types of sources and oscillators.

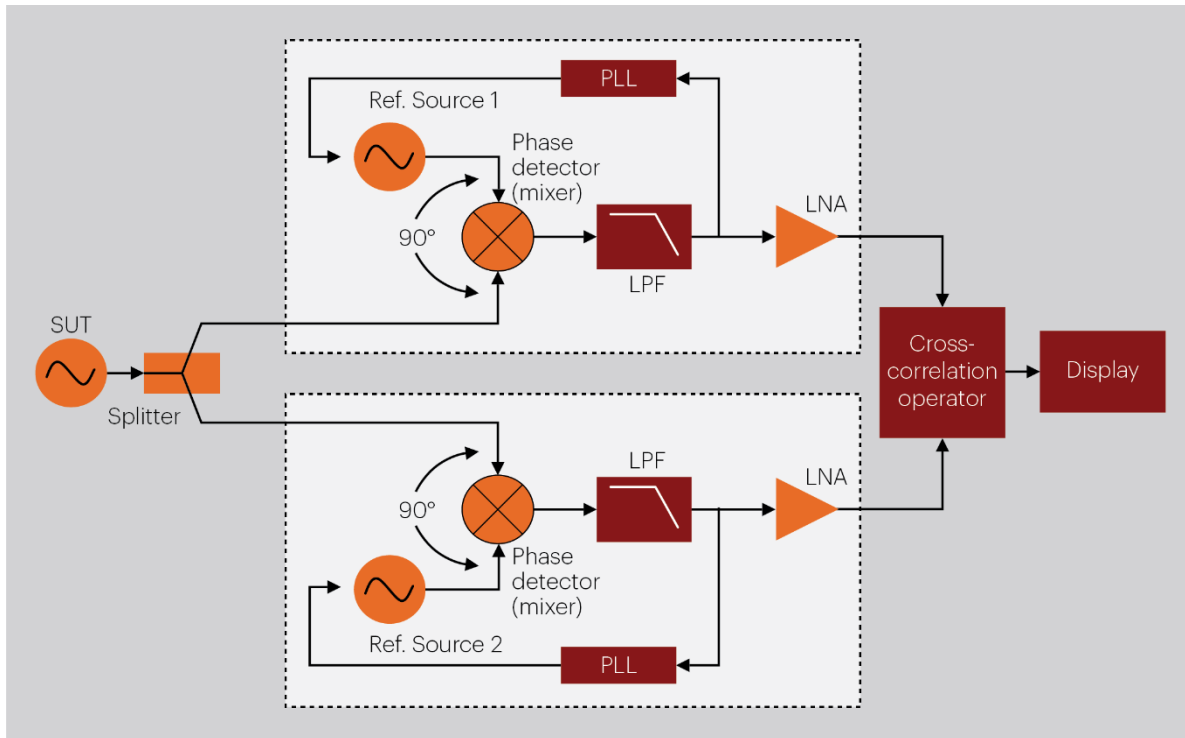

Figure 7. The two-channel cross-correlation technique utilizes two phase detectors.

Table 1. Increasing the number of cross-correlation operations will reduce the level of non-coherent noise.

Number of correlations	10	100	1,000	10,000
Noise reduction	-5 dB	-10 dB	-15 dB	-20 dB

Comparing

Phase noise measurement solutions

Currently, the range of available measurement solutions includes general-purpose spectrum analyzers such as the PXA, specialized instruments such as the E5052B SSA and PC-based modular systems such as the Keysight E5500 Series phase noise measurement system. The key differences center on capabilities, flexibility and performance, which affects the minimum and maximum offset frequencies the solution can achieve.

A Keysight X-Series signal analyzer—PXA, MXA or EXA—equipped with the optional N9068A phase noise measurement application is one way to implement the direct-spectrum approach (Figure 8). The application automatically performs the required carrier and noise measurements and then applies the necessary correction factors. The results can be presented as both a phase noise log plot (dBc/Hz versus log frequency) and a table of phase noise values at specific offset frequencies. This solution typically works well with offsets as close-in as 10 Hz or 100 Hz and as far-out as 10 MHz.

The E5052B SSA implements the more complex phase-detector or cross-correlation methods. The E5052B includes low-noise reference sources, an extremely low noise floor, and the DSP capabilities necessary to implement the heterodyne digital discriminator method and the two-channel cross-correlation technique. The SSA is well-suited to measurement offsets as low as 1 Hz and as high as 1 GHz. Its dedicated functionality enables easy operation and simplified setup and calibration.

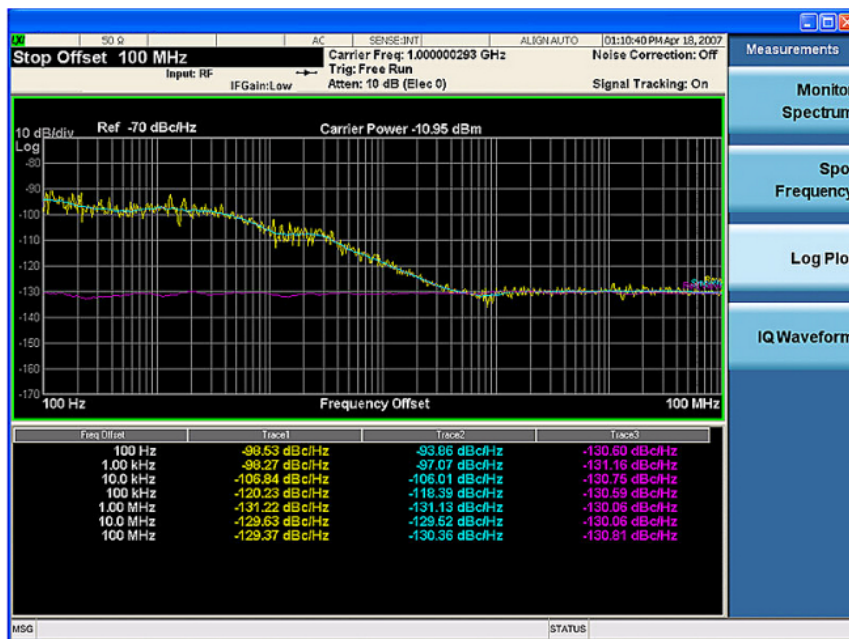

Figure 8. The N9068A application provides one-button measurements for the analysis of phase noise in the time and frequency domains.



Figure 9. The E5052B SSA supports measurements of AM noise and phase noise without changing the RF connection.

The E5500 modular solution can be configured to implement phase-detector techniques such as the reference-source/PLL method or the frequency-discriminator method with an analog delay line. In reference-source/PLL configuration, the E5500 has the performance and capabilities needed to measure very low phase noise at offsets as low as 0.01 Hz when used with a high-performance LO. In frequency-discriminator mode, the system can measure very low phase noise levels at far-out offset frequencies. The downside of this versatility: setup and calibration are more complicated than with the SSA- or signal analyzer-based approaches.

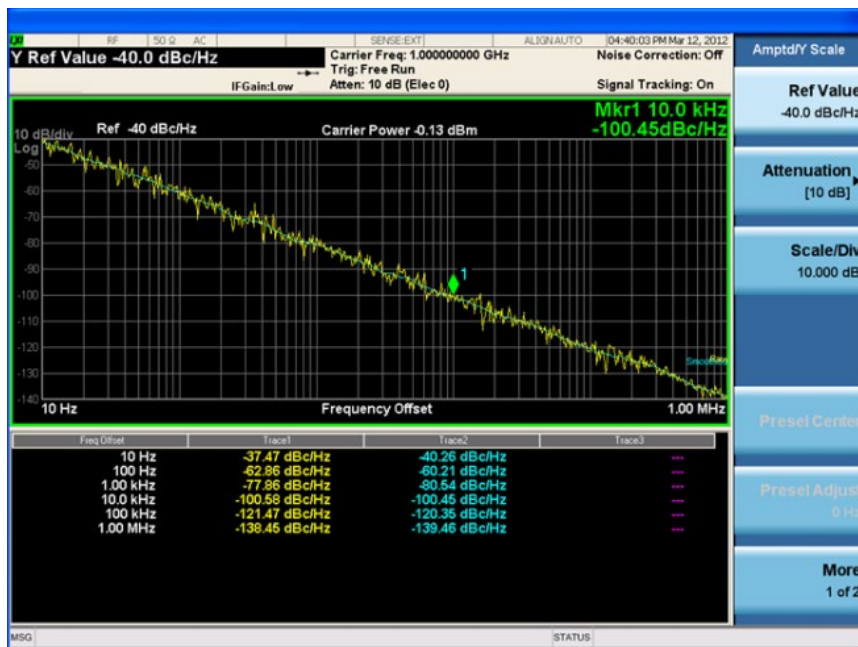

Figure 10. This uniform test signal can be used to verify the performance of a home-brew phase noise measurement solution.

Validating a home-brew solution

A calibrated phase noise signal can be used to verify a test setup. For example, a known-good reference is especially valuable when developing a direct-spectrum solution that includes self-written software that applies the necessary corrections. The approach described here is applicable to any phase noise measurement method.

A reliable test signal can be created by using uniform noise as the FM input to a signal generator. The slope of the noise sidebands will be constant at -20 dB per decade. The desired sideband level can be achieved by varying the deviation of the FM signal.

The example in Figure 10 was produced with a uniform noise signal frequency modulated at a 500 Hz rate. This produced phase noise value of -100 dBc/Hz at a 10 kHz offset.

Conclusion

Phase noise is one of the most important figures of merit for an RF or microwave signal-generating device. The nature of that device helps determine which method and solution is the most appropriate way to accurately measure phase noise.

The methods and solutions presented here are among the easiest and most cost-effective to implement. And while these approaches can provide excellent results for engineers who are not specialists in phase noise, an expert can help interpret results that may sometimes be quite puzzling.

Related information: Signal analyzers

Publication title	Pub number
Spectrum Analyzer Basics – Application Note	5952-0292EN
Reducing Phase Noise at RF and Microwave Frequencies – Application Note	5990-7529EN
Keysight's Phase Noise Measurement Solutions – Selection Guide	5990-5729EN
E5052B Signal Source Analyzer – Data Sheet	5989-6388EN
E5500 Series Phase Noise Measurement Solutions – Data Sheet	5989-0851EN
X-Series Signal Analysis – Product Brochure	5990-7998EN
PXA X-Series Signal Analyzer N9030A – Product Brochure	5990-3951EN
MXA X-Series Signal Analyzer N9020A – Product Brochure	5990-5047EN
EXA X-Series Signal Analyzer N9010A – Product Brochure	5989-6527EN
Phase Noise X-Series Measurement Application N9068A & W9068A – Technical Overview	5989-5354EN

Related information: Signal generators

Publication title	Pub number
MXG & EXG X-Series Signal Generators – Product Brochure	5990-9957EN
MXG X-Series Signal Generators, N5181B Analog & N5182B Vector – Data Sheet	5991-0038EN
EXG X-Series Signal Generators, N5171B Analog & N5172B Vector – Data Sheet	5991-0039EN
PSG Signal Generators – Product Brochure	5989-1324EN
E8257D PSG Microwave Analog Signal Generator – Data Sheet	5989-0698EN
E8267D PSG Vector Signal Generator – Data Sheet	5989-0697EN
E8663D PSG RF Analog Signal Generator – Data Sheet	5989-4136EN

Keysight enables innovators to push the boundaries of engineering by quickly solving design, emulation, and test challenges to create the best product experiences. Start your innovation journey at www.keysight.com.



This information is subject to change without notice. © Keysight Technologies, 2013 – 2024, Published in USA, January 16, 2024, 5991-2069EN